

Customer Approved
Date:

Part No.:
LE8503R6AGHB1C-A11T1

DATA SHEET

Issue Date: 2019.04.03
Issue No.: LTD-E8503-003
REVISION: V2

Designer	Checker	Approver
<i>Lisa</i>	<i>Rock</i>	<i>Allen</i>

LED Built-in IC Type ■ Top view Full-color 5050 Package LE8503R6AGHB1C-A11T1

Features

- Top SMD Integrated intelligent control chip.
- Support for single wire communication, serial connection.
- Constant current output current: 17mA
- Gray level adjustment circuit (256 gray level adjustable).
- Display data double latch, transfer data does not affect display
- Built-in high-precision oscillator.
- Display maximum refresh rate up to 10khz
- Pb-free
- RoHS compliant



Package Dimensions

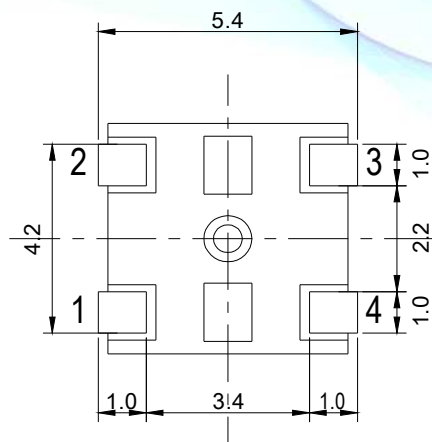
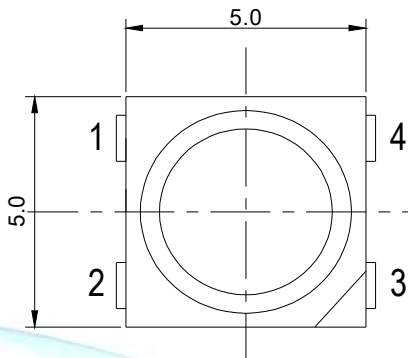

Recommended solder pad

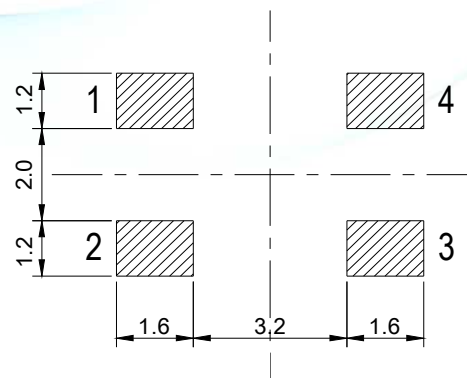

Note:

Tolerance unless mentioned is ± 0.1 mm, Unit = mm.

Applications

- LED point light source, LED pixel screen.
- LED fantasy soft light bar, LED fantasy color hard light bar.
- LED Phantom running Horse Lamp, LED Phantom Color guardrail Tube.
- LED Phantom Module Lamp, LED Phantom Lamp string.

Pin diagram and functions:

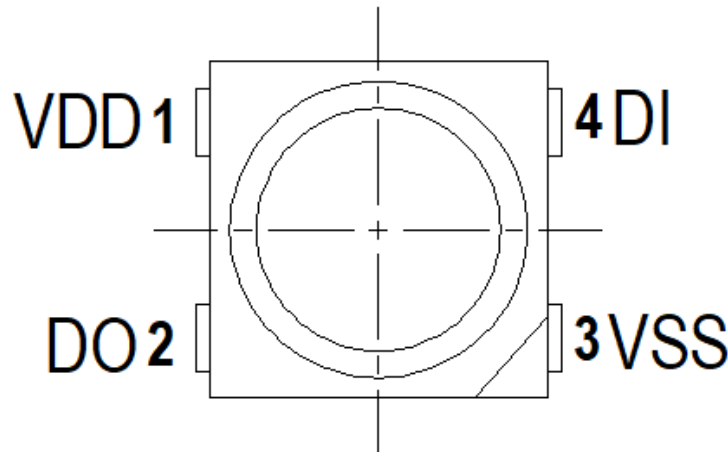

NO.	Symbol	Pin name	Function description
1	VDD	Power Supply	Chip power supply
2	DO	Data output	Data output port for cascading
3	VSS	Ground	Chip grounding
4	DIN	Data input	Data input port
/	G、R、B	Constant current output	/

Spectrum Distribution

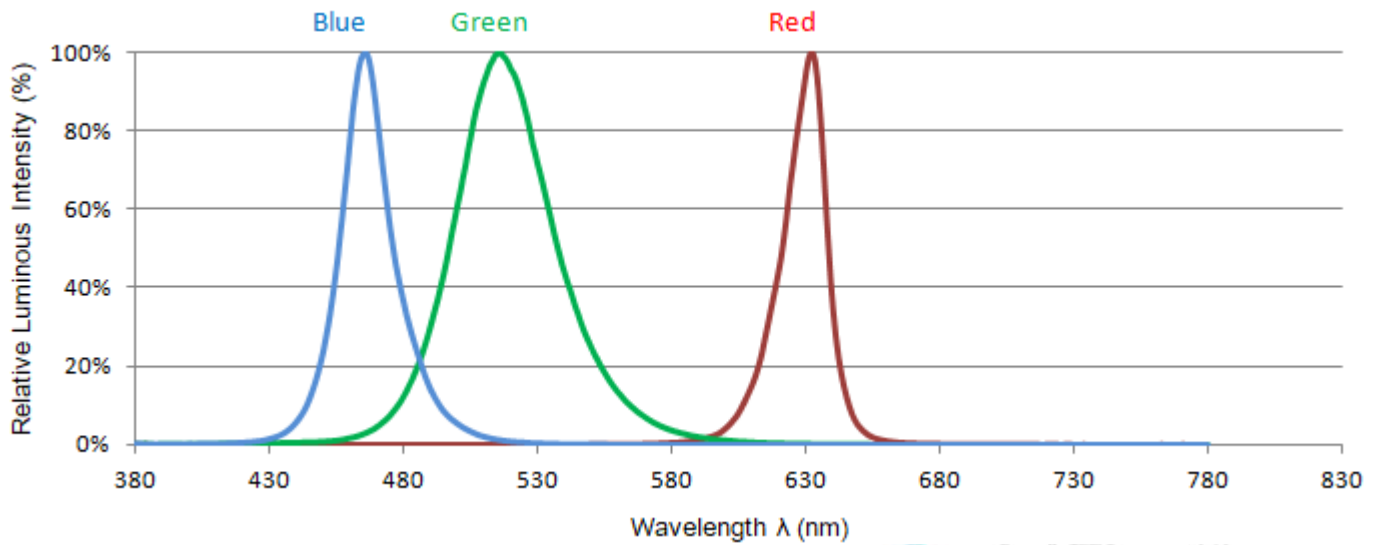

RGB LED Photoelectric parameters

Color	I _F =17mA	
	WD(nm)	I _v (mcd)
Red	620-625	500-700
Green	520-525	1400-2000
Blue	465-470	300-500

Electrical Characteristics (Limit parameter, T_a= 25 °C)

Parameter	Symbol	Range	Company
Input voltage	V _{In}	5~24	V
RGB Current output port voltage endurance	V _{DS}	26	V
Logical input voltage	V _{I1}	-0.5~5.5	V
R/G/B output current	I _{OL1}	17	mA
Power	PD	550	mW
Working temperature	T _{opt}	-40~+85	°C
Storage temperature	T _{stg}	-50~+150	°C
ESD voltage endurance	V _{ESD}	8K	V

Electrical Characteristics (Limit parameter, Ta = 25°C)

Parameter	Symbol	Min.	Avg.	Max.	Unit	Test conditions
Chip input voltage	V _{IN}	--	5	24	V	--
Internal power supply voltage	V _{DD}	--	5.2	--	V	--
R/G/B port voltage endurance	V _{DS,MAX}	--	--	26	V	OUT R/G/B
R/G/B port drive current	I _{OUT_R}	--	17	--	mA	I _{OUT_R} =1V
DOUT driving capability	I _{DOH}	--	49	--	mA	Dout port short ground, maximum drive current
	I _{DOL}	--	-50	--	mA	Dout port short VDD, maximum irrigation current
Signal input flip threshold	V _{IH}	--	3.4	--	V	VDD=5.0V
	V _{IL}	--	1.6	--	V	
R/G/B current variabl	%VS.V _{DS}	--	0.5	--	%	V _{DS} =1~5V,I _{OUT} =17 mA
	%VS.V _{DD}	--	0.3	--	%	V _{DD} =1~5V,I _{OUT} =17 mA
	%VS.Tem	--	4.0	--	%	V _{DS} =1~5V,I _{OUT} =17 mA,T _{em.} = -40~+85°C
R/G/B port voltage	V _{DS}	0.8	--	--	V	I _{OUT} =17 mA
PWM frequency	F _{PWM}	--	1.2	--	KHZ	--
Quiescent dissipation	I _{DD}	--	2.0	--	mA	--

Dynamic Parameter (Ta = 25°C) :

Parameter	Symbol	Min.	Avg.	Max.	Unit	Test conditions
Rate of data signalling	F _{DIN}	--	800	--	KHZ	Duty cycle 67%
DOUT transmission delay	T _{PLZ}	--	--	500	ns	DIN→DOUT
	T _{PLZ}	--	--	500	ns	
I _{OUT} rise time	T _r	--	32	--	ns	V _{DS} =1.5
	T _f	--	27	--	ns	I _{OUT} =17mA

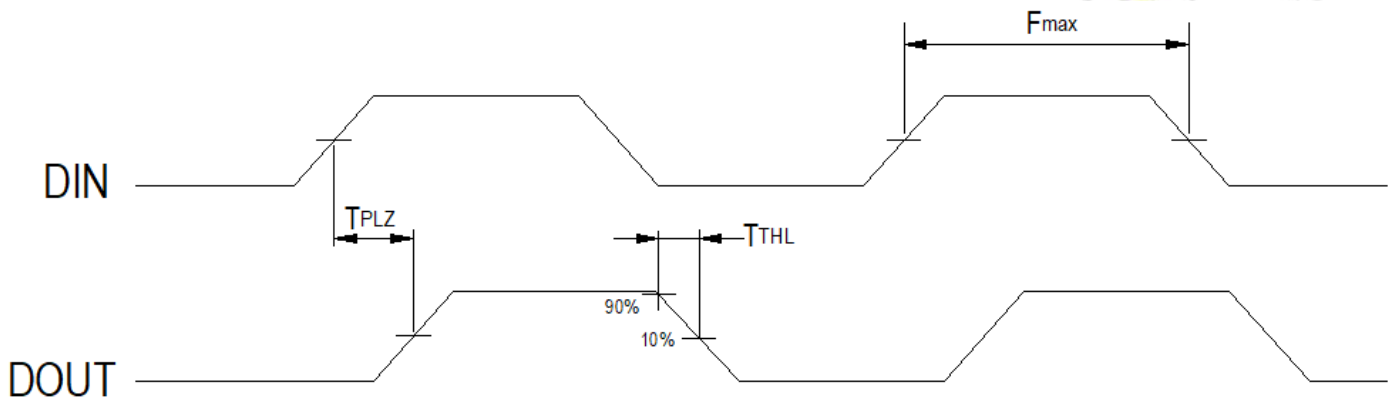

Coding description

The chip protocol uses unipolar return-to-zero code, each symbol must have a low level. Each symbol of this protocol starts at a high level, and the high-level time width determines the "0" code or "1" code.

Input code type:

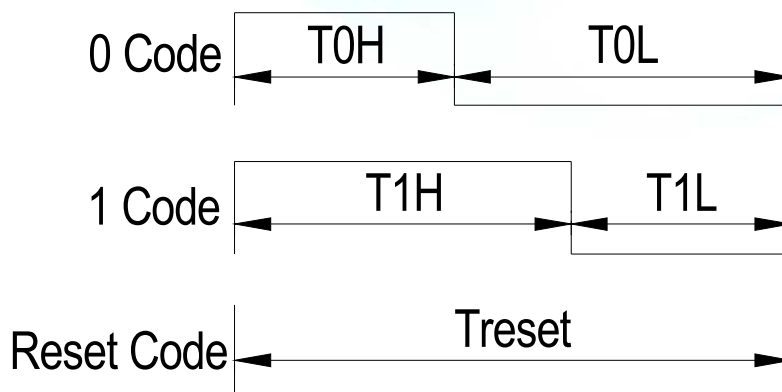

Data Transfer Time (VDD=5.0V)

Name	Description	Min.	Avg.	Max.	Admissible error	Unit
T0H	0 code, high level time	--	0.3	--	±0.05	us
T1H	1 code, high level time	--	0.9	--	±0.05	us
T0L	0 code, low level time	--	0.9	--	±0.05	us
T1L	1 code, low level time	--	0.3	--	±0.05	us
Trst	Reset code, low level time	--	80	--	--	us

Protocol data format:

High-level first, according to the order of the RGB to send the data.



bit:23

bit:0

DIN input data format: Trst the first chip 24bit gray-scale data, the second chip 24bit gray-scale data. 24bit grayscale data of the Nth Chip

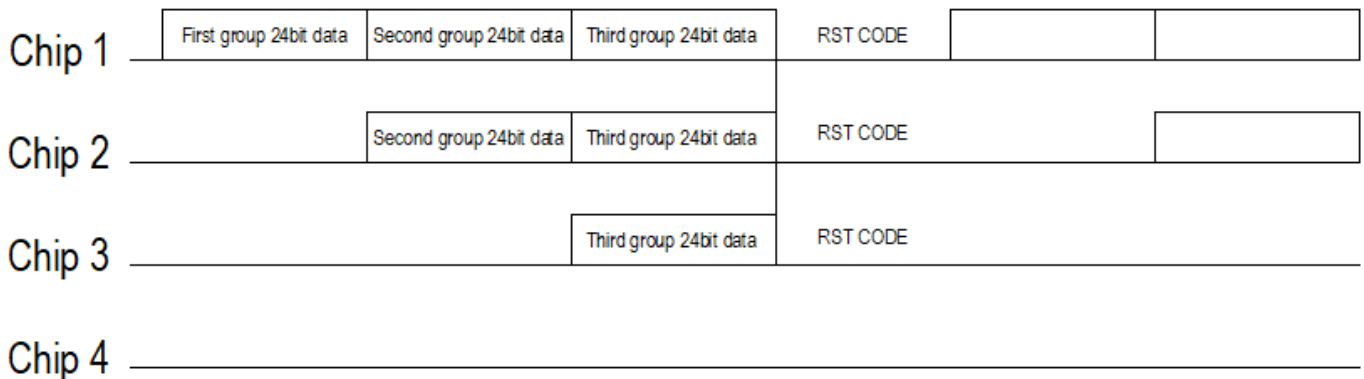
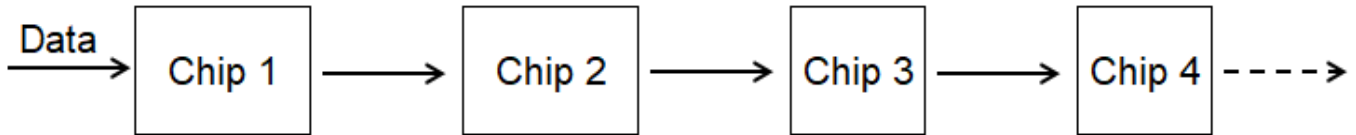

Higher-order working mode:

1. 5V Power supply single LED

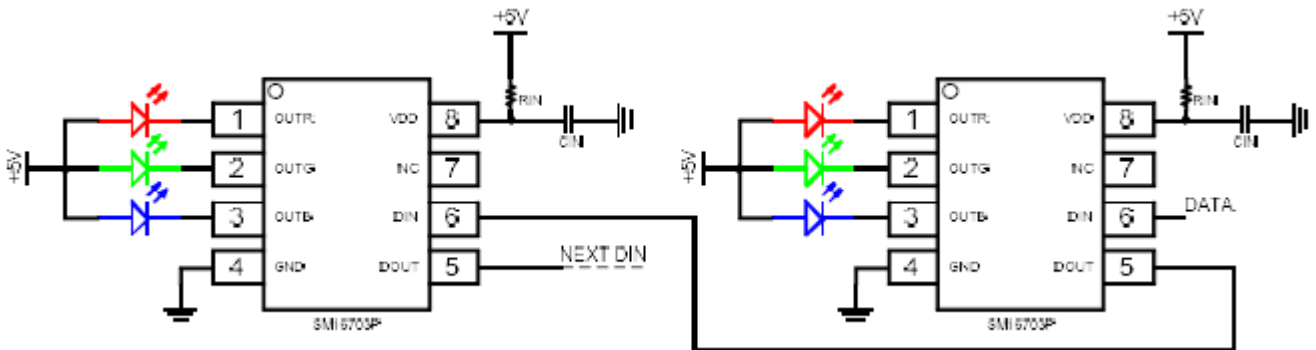

5V application scheme with fewer peripheral devices and up to 30m transmission distance between two points

2. 12V power supply 3 LED

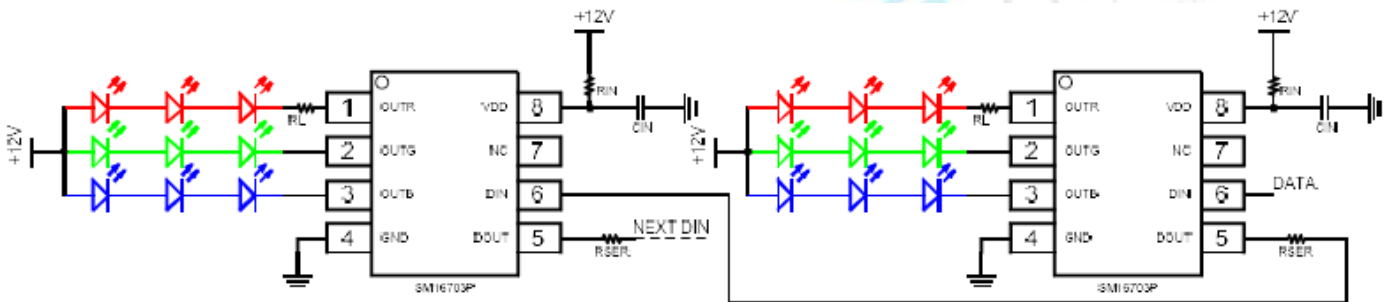

12V application scheme, it is recommended that 180 ohmic resistance R_{SER} is serially connected to the signal output port to prevent damage to the IC output terminal in the case of live hot plug or power supply and signal wire reverse connection, and the transmission distance between the two points of 180 ohmic resistor R_{SER} can be up to 10m.

3. 24V Power supply 6 LED

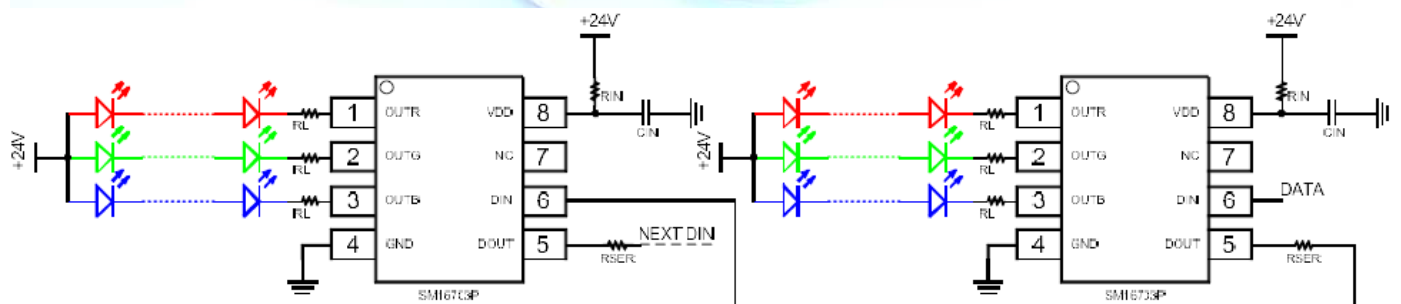

24V application scheme, it is recommended that the signal output port is serially connected with 470ohm resistance R_{SER} to prevent damage to the IC output terminal in the case of live hot plug or power supply and signal wire reverse connection, and the transmission distance between the two points of 470ohm resistance R_{SER} can be up to 5 m.

Moisture Resistant Packing Materials

Label Explanation



- * QR code:
Contains all of the following information
- * P/N: Product Number
- * TYPE :Part NO.
- * IV: /
- * WD: /
- * VF: /
- * QTY: Packing Quantity
- * LOT NO.: Lot Number

Taping method: Loaded Quantity 1,000 pcs Per Reel

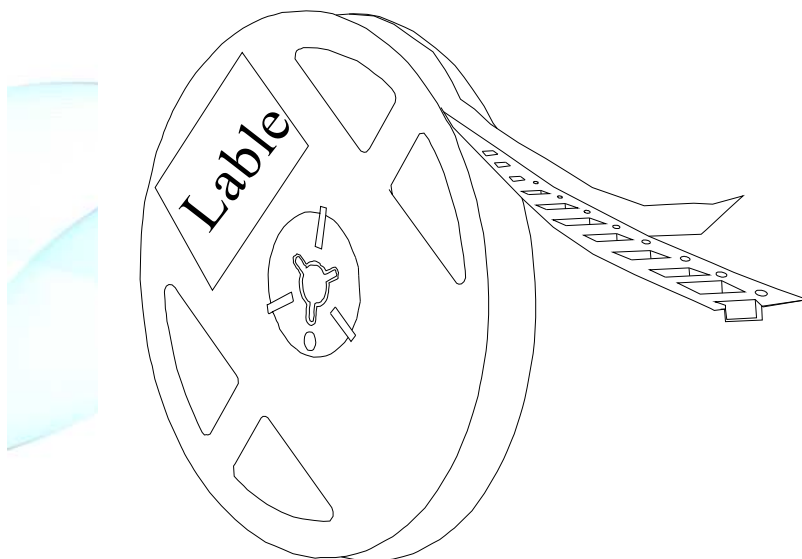

Direction of unreeling →

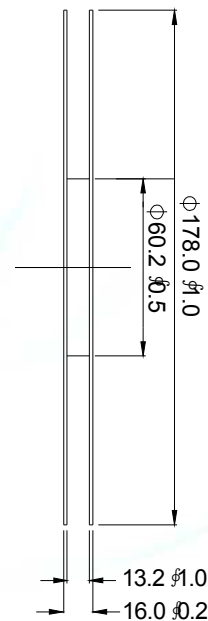

Notes:

- 1.Tolerance unless mentioned is ±0.1mm,Unit = mm.
- 2.Minimum packing amount is 500 pcs per reel.

Carrier Tape Dimensions:

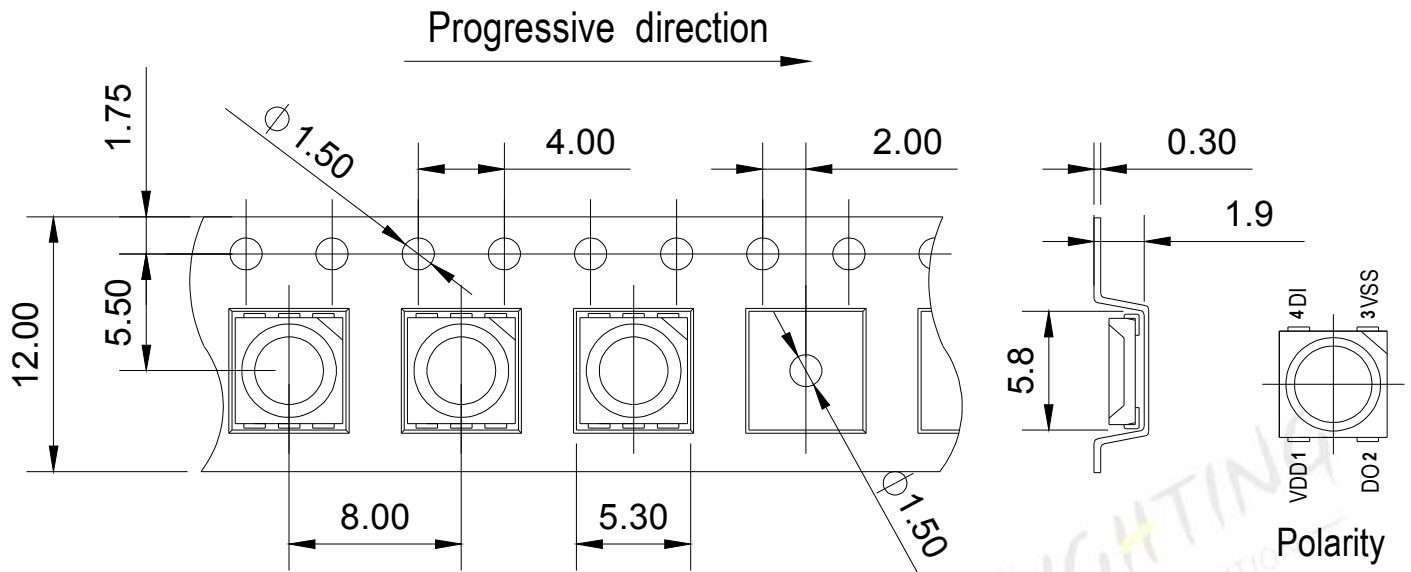

Note:
Tolerance unless mentioned is ± 0.1 mm, Unit = mm.

Moisture Resistant Packing Process

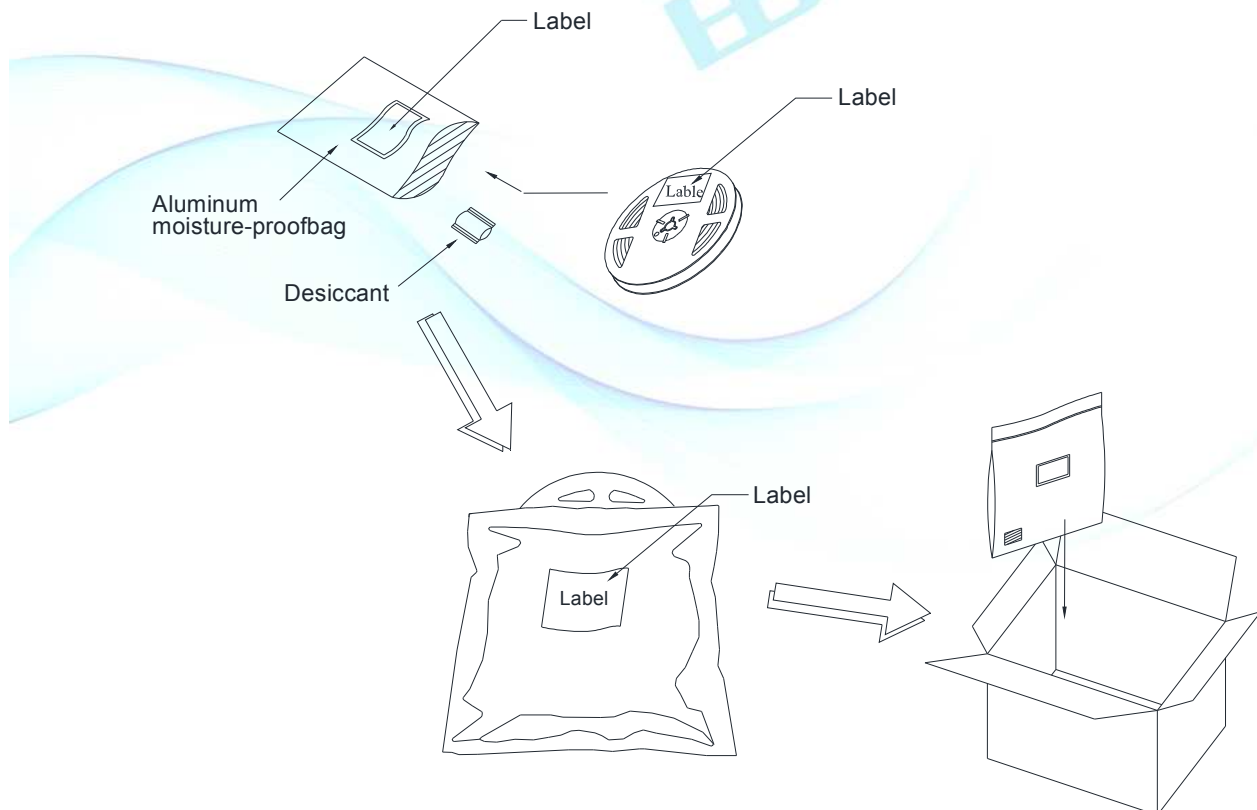

Moisture/Reflow sensitivity classification
IPC / JEDEC J-STD-020C: Level 5

Reliability Test Items and Conditions

The reliability of products shall be satisfied with items listed below.

Confidence level : 90%

LTPD : 10%

No.	Items	Test Condition	Test Hours/Cycles	Sample Size	Ac/Re
1	Reflow Soldering	Temp.: 260°C/10sec.	6 Min.	22 PCS.	0/1
2	Thermal Shock	H : +100°C/5min ∫ 10 sec L : -10°C/5min	300 Cycles	22 PCS.	0/1
3	Temperature Cycle	H : +100°C/15min ∫ 5 min L : -40°C/15min	300 Cycles	22 PCS.	0/1
4	High Temperature/Humidity Storage	Ta=85°C,85%RH	1000 Hrs.	22 PCS.	0/1
5	Low Temperature Storage	Ta=-40°C	1000 Hrs.	22 PCS.	0/1
6	High Temperature Storage	Ta=100°C	1000 Hrs.	22 PCS.	0/1
7	DC Operation Life	Ta=25°C, VDD = 5 V	1000 Hrs.	22 PCS.	0/1



Precautions for Use

1. Over-current-proof

Customer must apply resistors for protection; otherwise slight voltage shift will cause big current change (Burn out will happen).

2. Storage

2.1 Do not open moisture proof bag before the products are ready to use.

2.2 Before opening the package: The LEDs should be kept at 30°C or less and 60%RH or less.

2.3 After opening the package: The LED's floor life is 48 hours under 30°C or less and 30-35%%RH or less.

2.4 If the moisture absorbent material (silica gel) has faded away or the LEDs have exceeded the storage time, baking treatment should be performed using the following conditions.

Baking treatment: 60±5°C for 24 hours. .

2.5 Acid, alkali and corrosive gas should be avoided in storage environment and intensively shock and high magnetic field also avoided.

3. Soldering Condition

3.1 Pb-free solder temperature profile

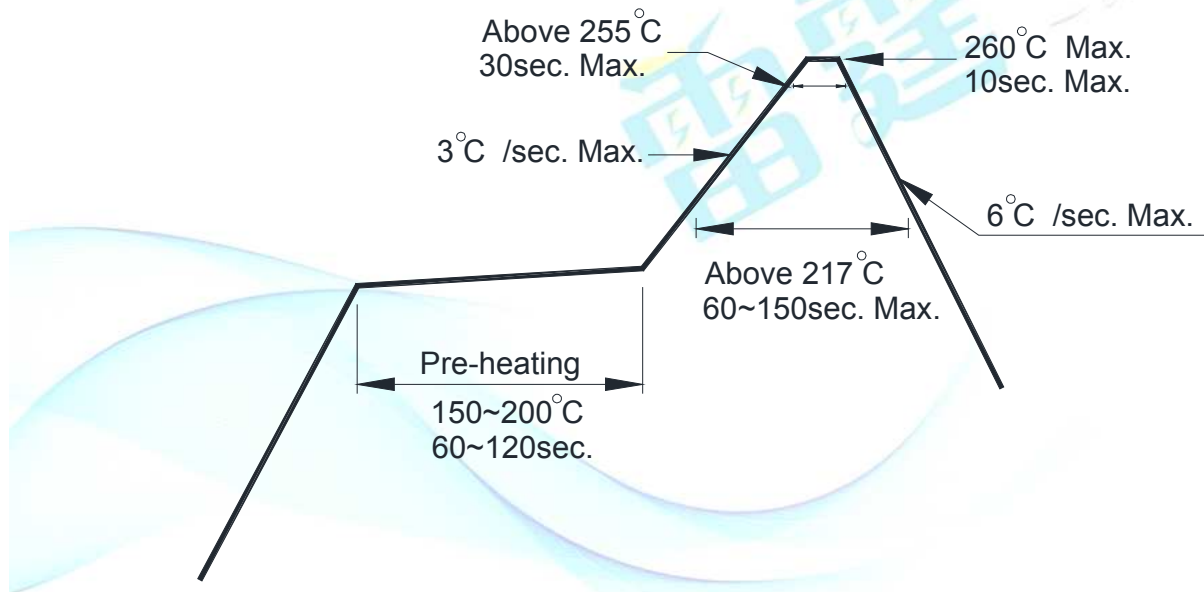

3.2 Reflow soldering should not be done more than two times.

3.3 When soldering, do not put stress on the LEDs during heating.

3.4 After soldering, do not warp the circuit board.

4. Soldering Iron

Each terminal is to go to the tip of soldering iron temperature less than 350°C for 3 seconds within once in less than the soldering iron capacity 25W. Leave two seconds and more intervals and do soldering of each terminal. Be careful because the damage of the product is often started at the time of the hand solder.

5. Repairing

Repair should not be done after the LEDs have been soldered. When repairing is unavoidable, a double-head soldering iron should be used (as below figure). It should be confirmed beforehand whether the characteristics of the LEDs will or will not be damaged by repairing.