

Customer Approved
Date:

Part No.:
LL820W1D-J05T4

DATA SHEET

Issue Date: 2019.06.10

Issue No.: LTD-820-001

REVISION: V3

Designer	Checker	Approver
<i>Lisa</i>	<i>Rock</i>	<i>Allen</i>

Flash LED Type ■ Top view 2016 Package
LL820W1D-J05T4

Features

- 2016 package
- Top view LED
- High luminous flux output
- Compatible with infrared and vapor phase reflow solder process
- Pb-free
- RoHS compliant

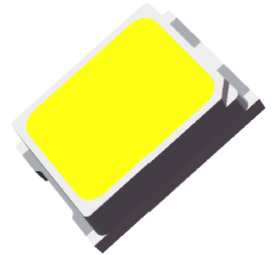

Package Dimensions

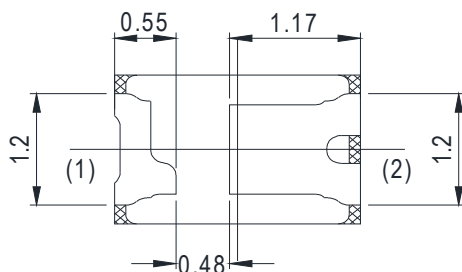
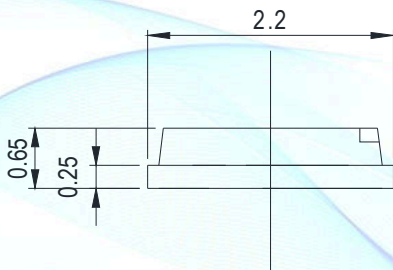
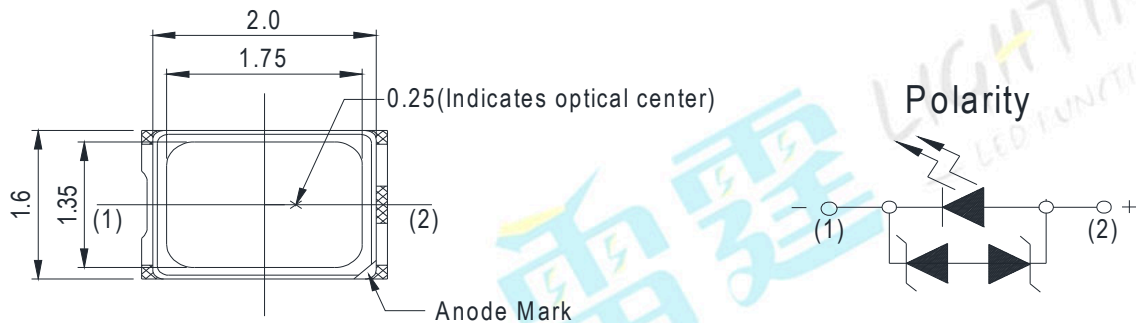

Note:
Tolerance unless mentioned is ± 0.1 mm, Unit = mm.

Recommended Solder Pad

Compatible Design

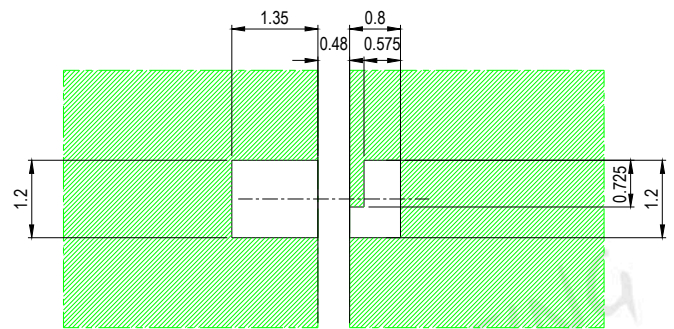
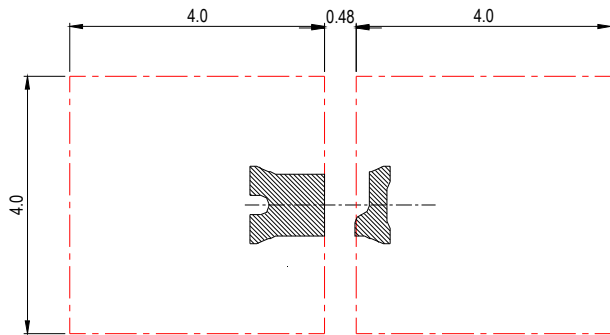

■ footprint □ Cu area (Min: 16 mm²)
(Cu plating layer Min: 15 um)

■ solder resist

Component Location on pad

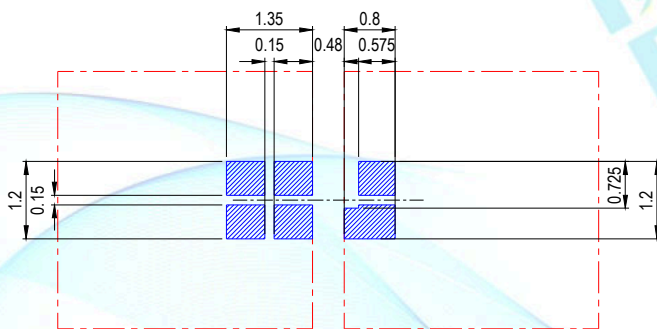

■ solder stencil

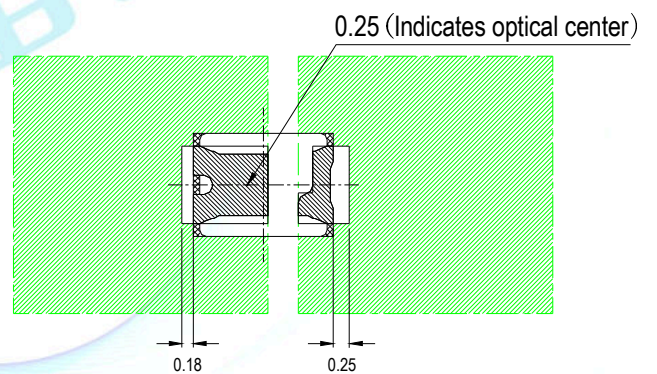

Note:
Tolerance unless mentioned is ± 0.05 mm, Unit = mm.

Applications

- Flash lights
- General lighting
- Decorative and Entertainment Lighting
- Indicators
- Illumination
- Automotive Telecommunication
- Switch lights

Device Selection Guide

Emitted Color	Resin Color
White	Yellow Diffused

Absolute Maximum Ratings (T_{Soldering}=25°C)

Parameter	Symbol	Rating	Unit
Forward Current	I _F	350	mA
Peak Forward Current (T=1.3s, tp=0.3s)	I _{FP}	800	mA
Power Dissipation	P _d	3.0	W
Electrostatic Discharge(HBM)	ESD	8000	V
Thermal Resistance(junction to case)	R _s	12	°C/W
Junction Temperature	T _j	120	°C
Operating Temperature	T _{opr}	-40 ~ +85	°C
Storage Temperature	T _{stg}	-40 ~ +100	°C
Soldering Temperature	T _{sol}	Reflow Soldering : 260 °C for 10 sec. Hand Soldering : 350 °C for 3 sec.	
Reverse Voltage	V _R	5	V

Electro-Optical Characteristics (T_{Soldering}=25°C)

Parameter	Symbol	Min.	Typ.	Max.	Unit	Condition
Luminous Flux	Φ	100	130	180	lm	I _F =350mA
Luminous Flux* ³	Φ	160	200	-----	lm	I _{FP} =650mA
Luminous Flux* ³	Φ	180	220	-----	lm	I _{FP} =800mA
Luminance* ³ (At 1 meter of center)	E	60	75	-----	lux	I _{FP} =650mA
Luminance* ^{3*4} (At 1 meter of center)	E	68	85	-----	lux	I _{FP} =800mA
Forward Voltage	V _F	2.75	3.25	3.65	V	I _F =350mA
Forward Voltage* ³	V _F	-----	3.65	-----	V	I _{FP} =650mA
Forward Voltage* ^{3*4}	V _F	-----	3.75	-----	V	I _{FP} =800mA
CRI	----	-----	80	-----		I _{FP} =800mA
Viewing Angle	2θ _{1/2}	-----	120	-----	deg	I _F =350mA
Reverse Current	I _R	-----	-----	1	μA	V _R =5V

Bin Code Description

Bin Range of Luminous Flux

Bin Code	Min.	Max.	Unit	Condition
L53	100	110	lm	I _F =350mA
L54	110	120		
L55	120	130		
L56	130	140		
L57	140	160		
L58	160	180		

Bin Range of Forward Voltage

Bin Code	Min.	Max.	Unit	Condition
5	2.75	3.05	V	I _F =350mA
6	3.05	3.35		
7	3.35	3.65		

Notes:

1. Tolerance of Luminous Flux: ±10%.
2. Tolerance of Forward Voltage : ±0.1V.
3. Peak Forward Current (T=1.3s, tp=0.3s)
4. In the I_{FP}=800mA, the voltage will be higher than the I_F=350mA, it is approximately 0.5V.

Bin Range of Chromaticity Coordinates

Bin Code	CIE_x	CIE_y
A	0.3171	0.344
	0.3454	0.3725
	0.3421	0.3319
	0.3204	0.3092

Notes:

1. The value is based on driving current by 350mA.
2. Tolerance of Chromaticity Coordinates: ± 0.01 .

The C.I.E. 1931 Chromaticity Diagram

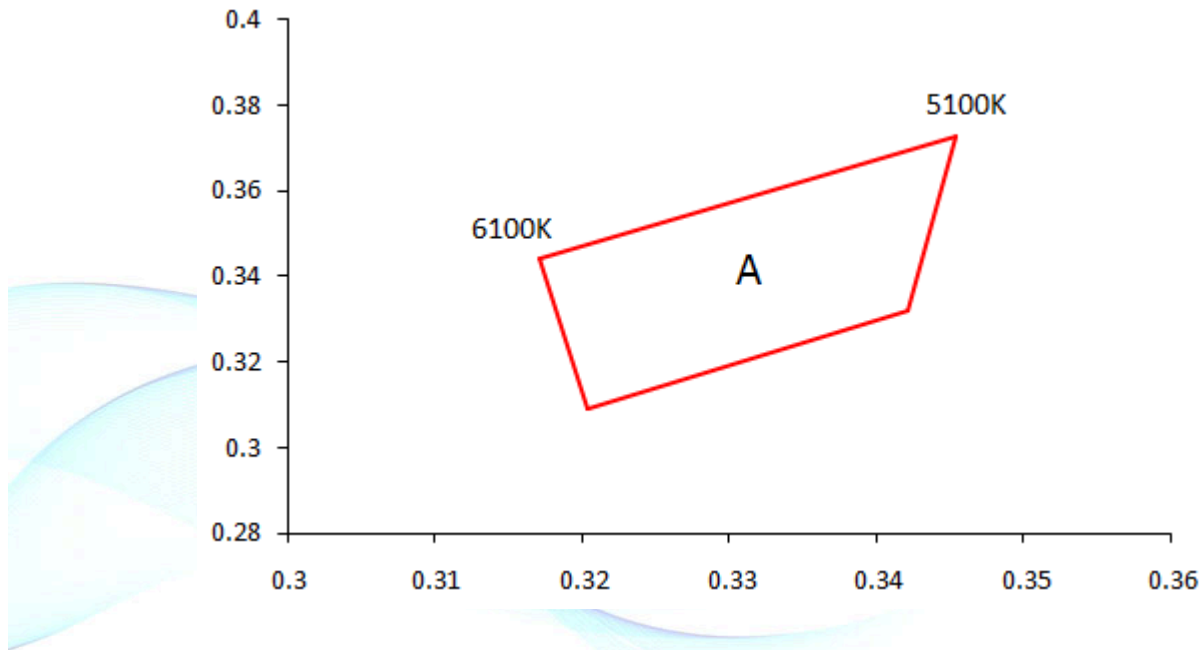

Typical Electro-Optical Characteristics Curves

Fig.1-Forward Current(I) vs. Forward Voltage $T_s=25^\circ\text{C}$

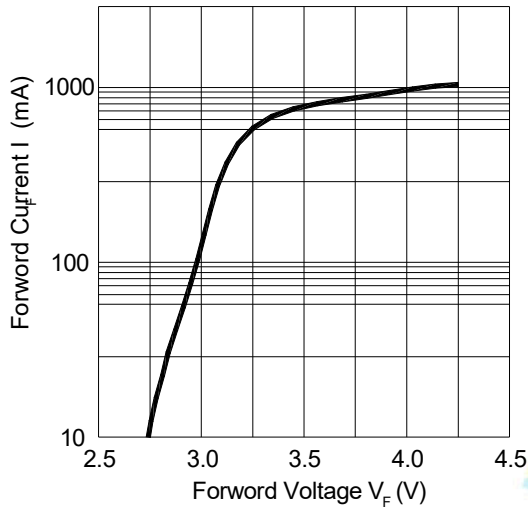

Fig.2-Relative Luminous Flux vs. Forward Current $T_s=25^\circ\text{C}$

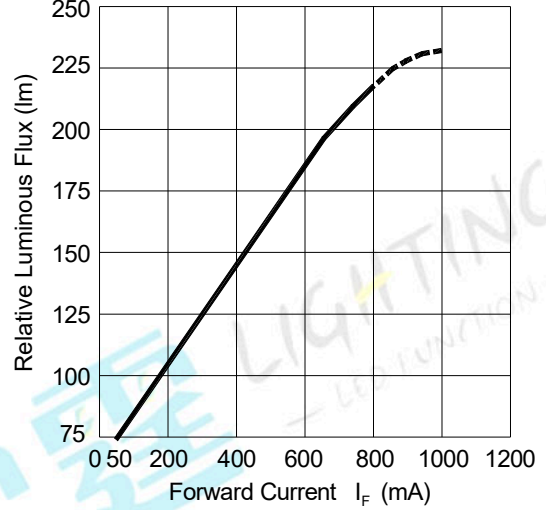

Fig.3-Max. Driving Forward Current vs. Soldering Temperature

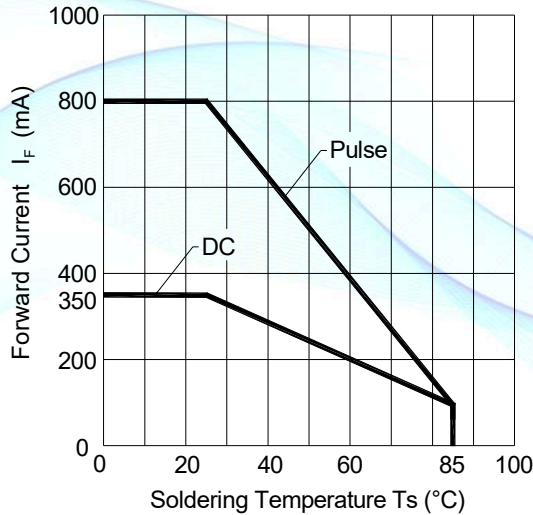
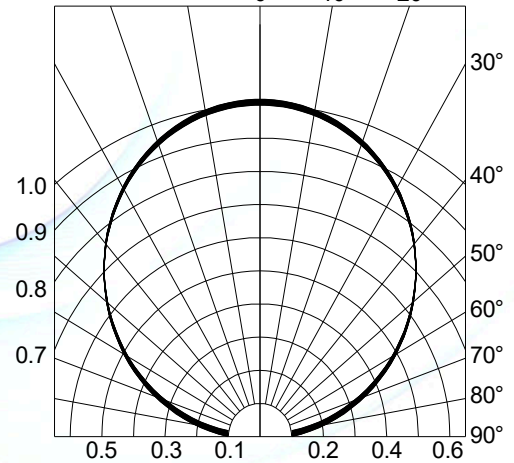

Fig.4-Radiation Diagram $T_a=25^\circ\text{C}$



Typical Electro-Optical Characteristics Curves

Fig.5-Forward Voltage Shift vs. Junction Temperature

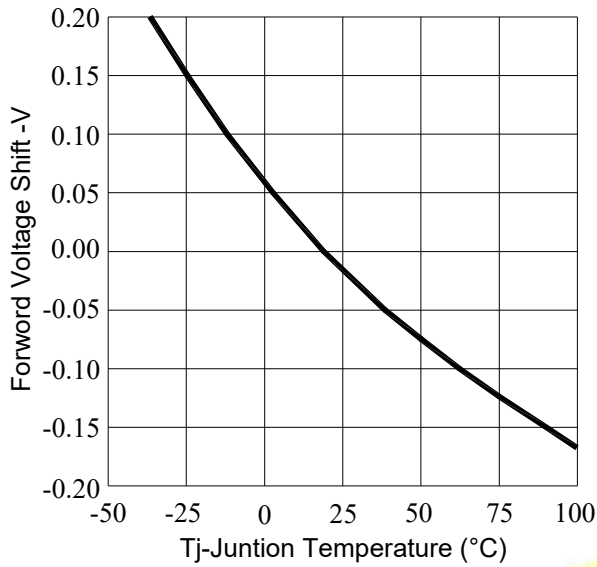
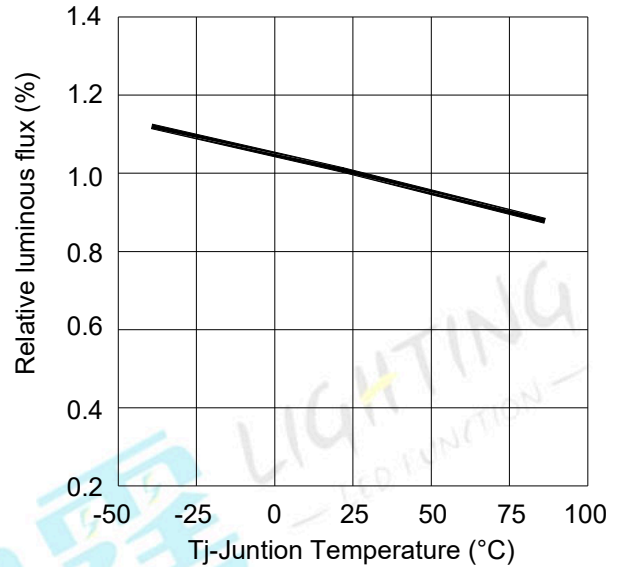
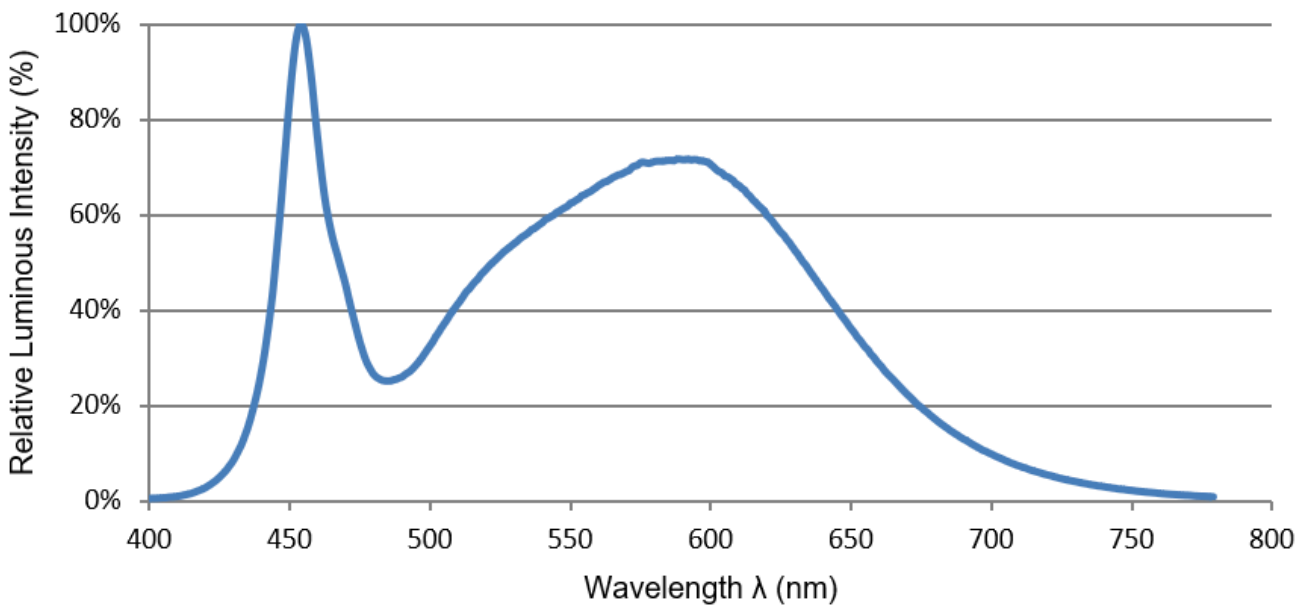

Fig.6-Relative Luminous Flux vs. Junction Temperature



Spectrum Distribution



**Moisture Resistant Packing Materials
Label Explanation**



- * QR code:
Contains all of the following information
- * P/N: Product Number
- * TYPE :Part NO.
- * IV: Luminous Flux Rank
- * HUE: Chromaticity Coordinates Rank
- * VF: Forward Voltage Rank
- * QTY: Packing Quantity
- * LOT NO.: Lot Number

Taping method: Loaded Quantity 4,000 pcs Per Reel

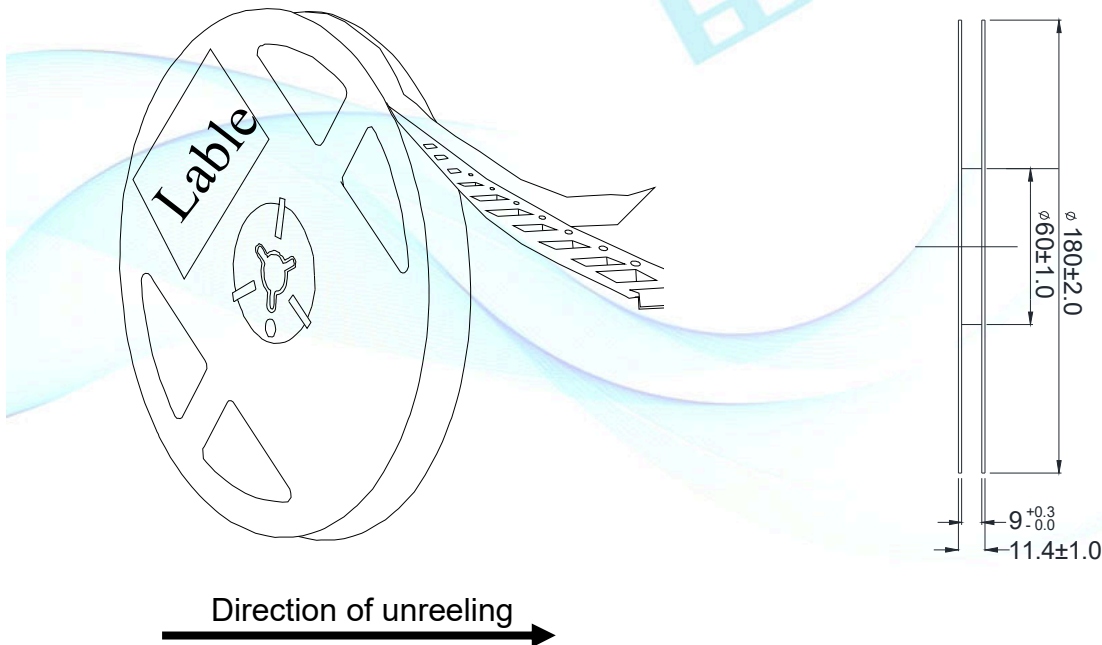

Notes:

1. Tolerance unless mentioned is ± 0.1 mm, Unit = mm.
2. Minimum packing amount is 1000 pcs per reel.

Carrier Tape Dimensions:

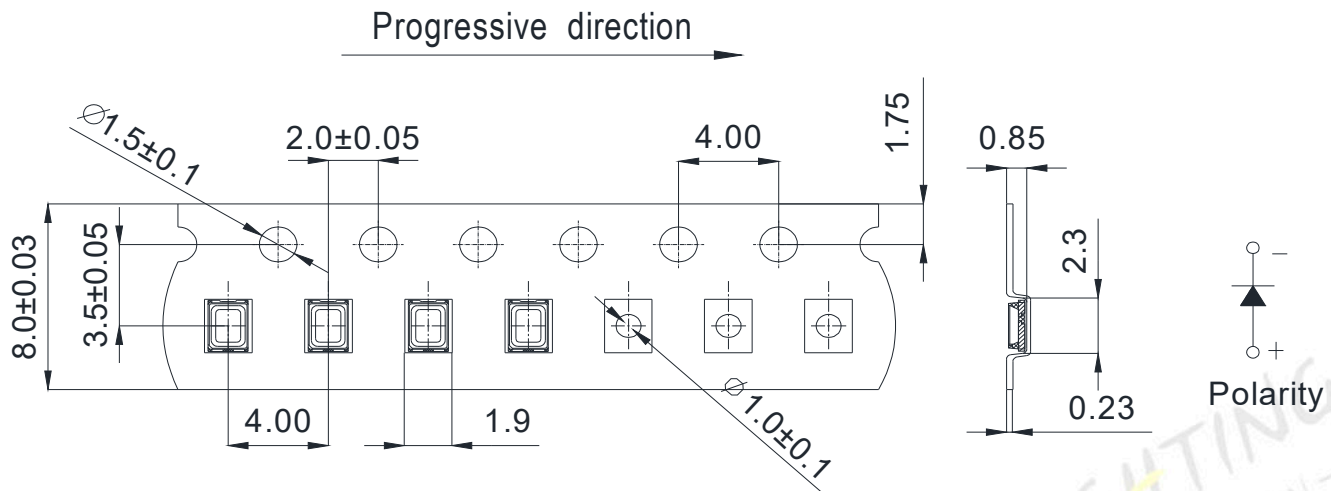

Note:
Tolerance unless mentioned is ± 0.1 mm, Unit = mm.

Moisture Resistant Packing Process

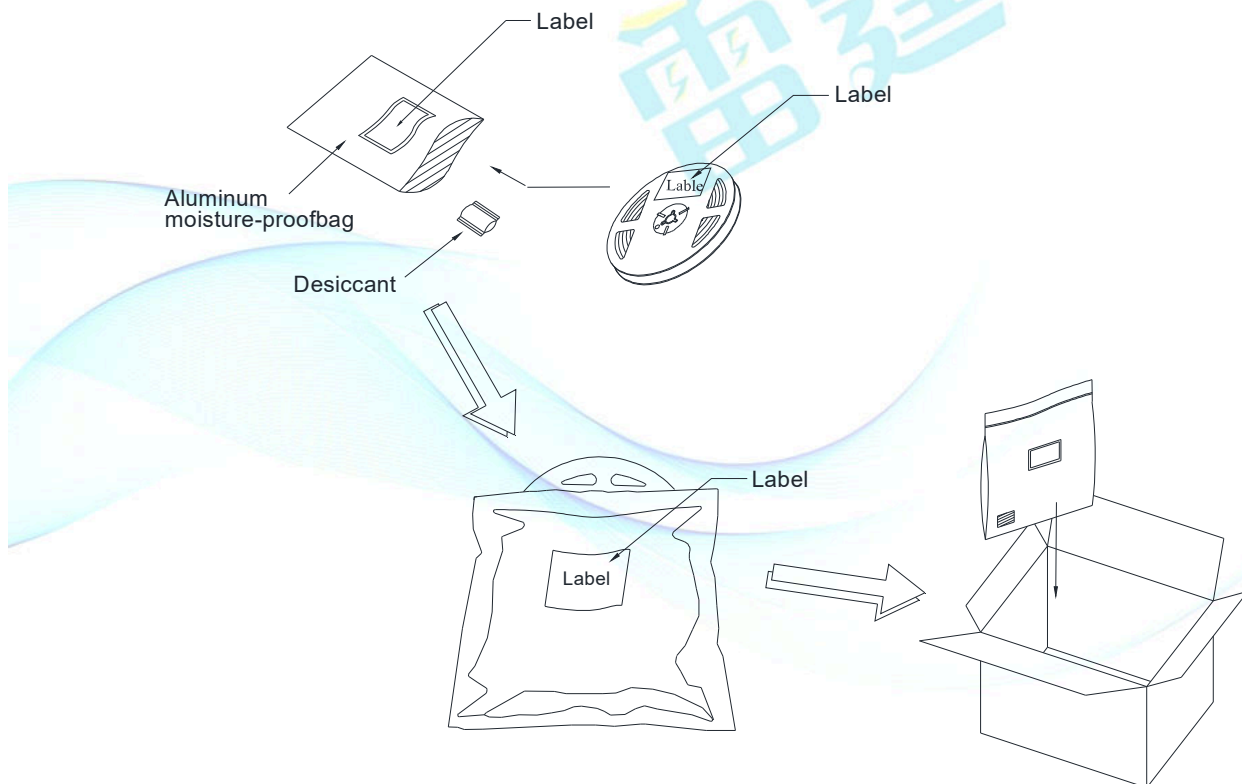

Moisture/Reflow sensitivity classification
IPC / JEDEC J-STD-020C: Level 3

Reliability Test Items and Conditions

The reliability of products shall be satisfied with items listed below.

Confidence level : 90%

LTPD : 10%

No.	Items	Test Condition	Test Hours/Cycles	Sample Size	Ac/Re
1	Reflow Soldering	Temp.: 260°C/10sec.	6 Min.	22 PCS.	0/1
2	Thermal Shock	H : +100°C/5min § 10 sec L : -10°C/5min	300 Cycles	22 PCS.	0/1
3	Temperature Cycle	H : +100°C/15min § 5 min L : -40°C/15min	300 Cycles	22 PCS.	0/1
4	High Temperature/Humidity Storage	Ta=85°C,85%RH	1000 Hrs.	22 PCS.	0/1
5	Low Temperature Storage	Ta=-40°C	1000 Hrs.	22 PCS.	0/1
6	High Temperature Storage	Ta=100°C	1000 Hrs.	22 PCS.	0/1
7	DC Operation Life	Ta=25°C, I _F = 350 mA	1000 Hrs.	22 PCS.	0/1
8	Peak Forward Current Operation Life (T=1.3s, tp=0.3s)	Ta=25°C, I _{FP} = 800 mA	100000 cycles	5 PCS	0/1

Precautions for Use

1. Over-current-proof

Customer must apply resistors for protection; otherwise slight voltage shift will cause big current change (Burn out will happen).

2. Storage

2.1 Do not open moisture proof bag before the products are ready to use.

2.2 Before opening the package: The LEDs should be kept at 30°C or less and 90%RH or less.

2.3 After opening the package: The LED's floor life is 168H under 30°C or less and 60%RH or less. If unused LEDs remain, it should be stored in moisture proof packages.

2.4 If the moisture absorbent material (silica gel) has faded away or the LEDs have exceeded the storage time, baking treatment should be performed using the following conditions.

Baking treatment: 60±5°C for 24 hours.

3. Soldering Condition

3.1 Pb-free solder temperature profile

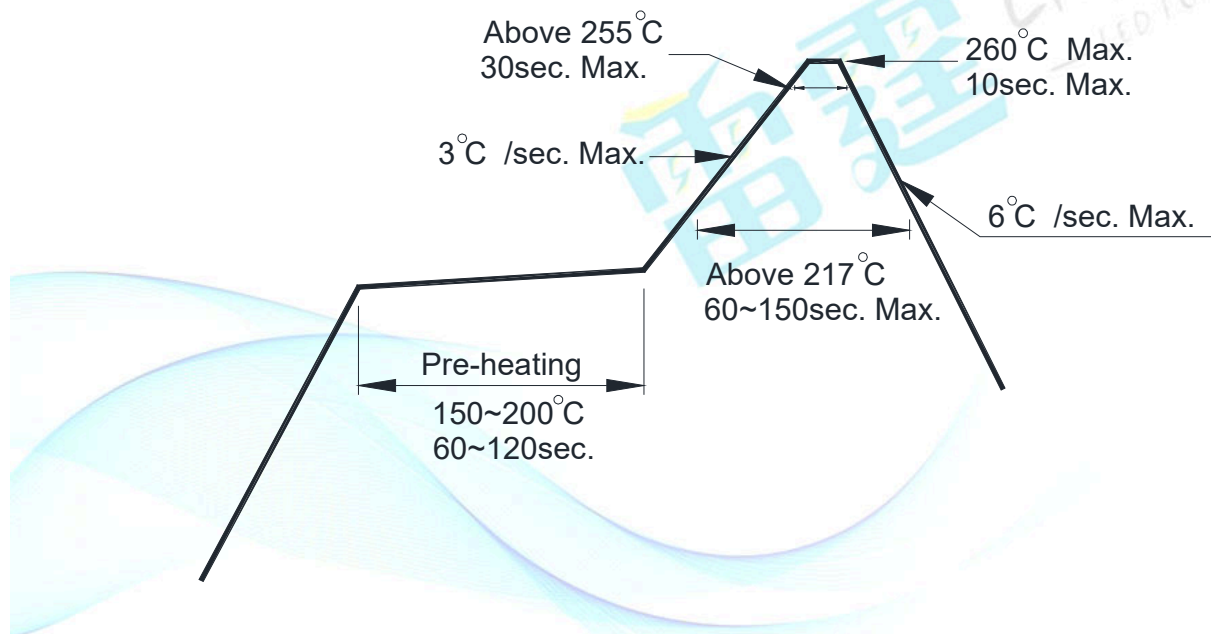

3.2 Reflow soldering should not be done more than two times.

3.3 When soldering, do not put stress on the LEDs during heating.

3.4 After soldering, do not warp the circuit board.

4. Soldering Iron

Each terminal is to go to the tip of soldering iron temperature less than 350°C for 3 seconds within once in less than the soldering iron capacity 25W. Leave two seconds and more intervals and do soldering of each terminal. Be careful because the damage of the product is often started at the time of the hand solder.

5. Repairing

Repair should not be done after the LEDs have been soldered. When repairing is unavoidable, a double-head soldering iron should be used (as below figure). It should be confirmed beforehand whether the characteristics of the LEDs will or will not be damaged by repairing