

<b>Customer Approved</b>
<b>Date:</b>

**Part No.:**  
**LL828W1D-QV3T4**

**DATA SHEET**

Issue Date: 2019.06.11

Issue No.: LTD-828-002

REVISION: V2

Designer	Checker	Approver
<i>Vic</i>	<i>Rock</i>	<i>Jeff</i>

Flash LED Type ■ Top view 2016 Package  
LL828W1D-QV3T4

**Features**

- 2016 package
- Top view LED
- High luminous flux output
- Compatible with infrared and vapor phase reflow solder process
- Pb-free
- RoHS compliant

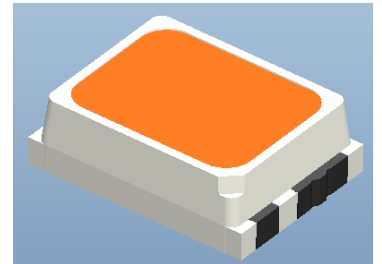

**Package Dimensions**

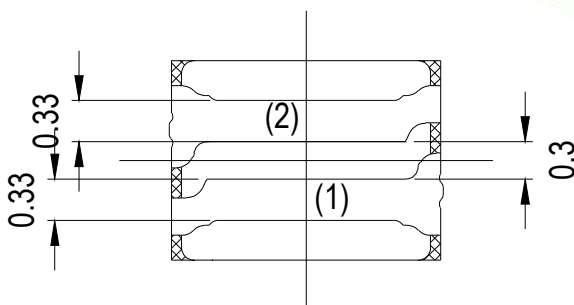
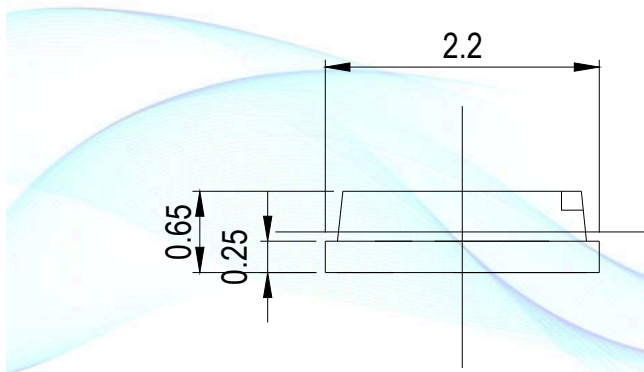
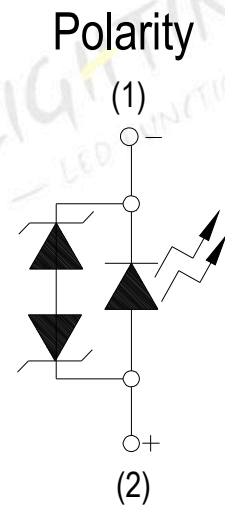
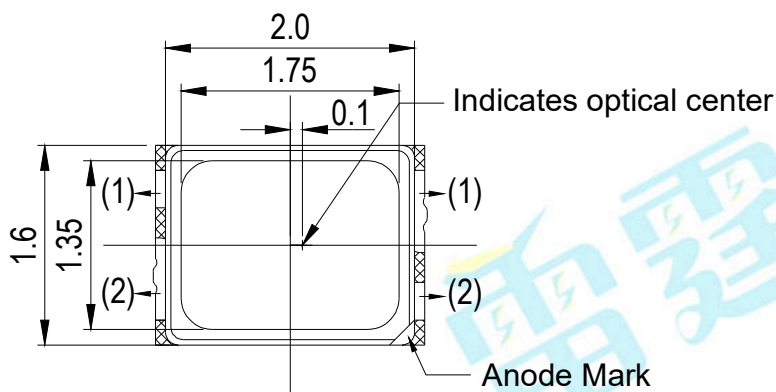

Note:  
Tolerance unless mentioned is  $\pm 0.1$ mm, Unit = mm.

**Recommended Solder Pad**

**Compatible Design**

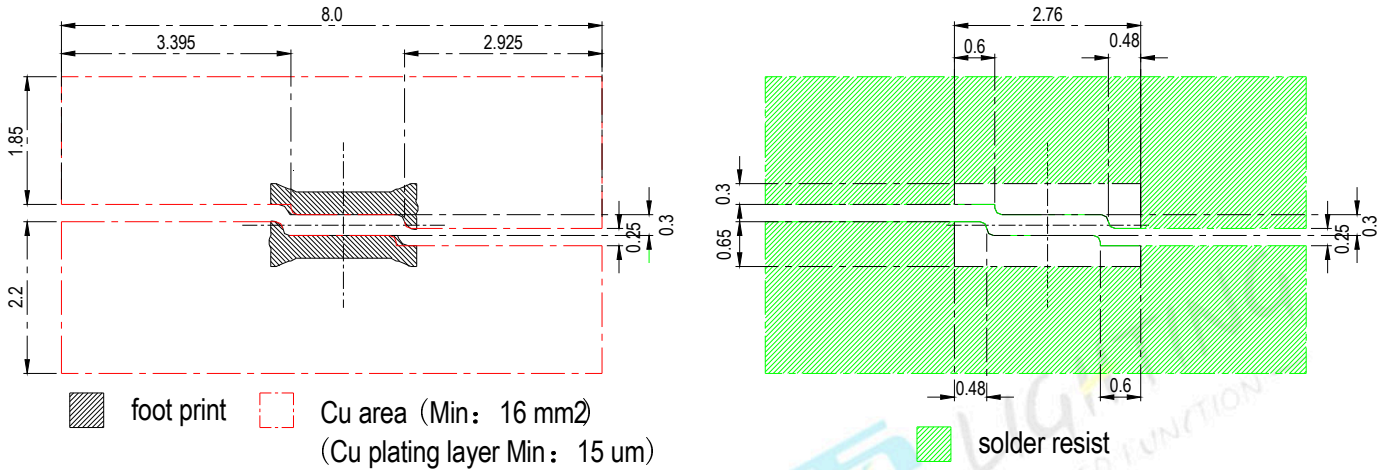

**Component Location on pad**

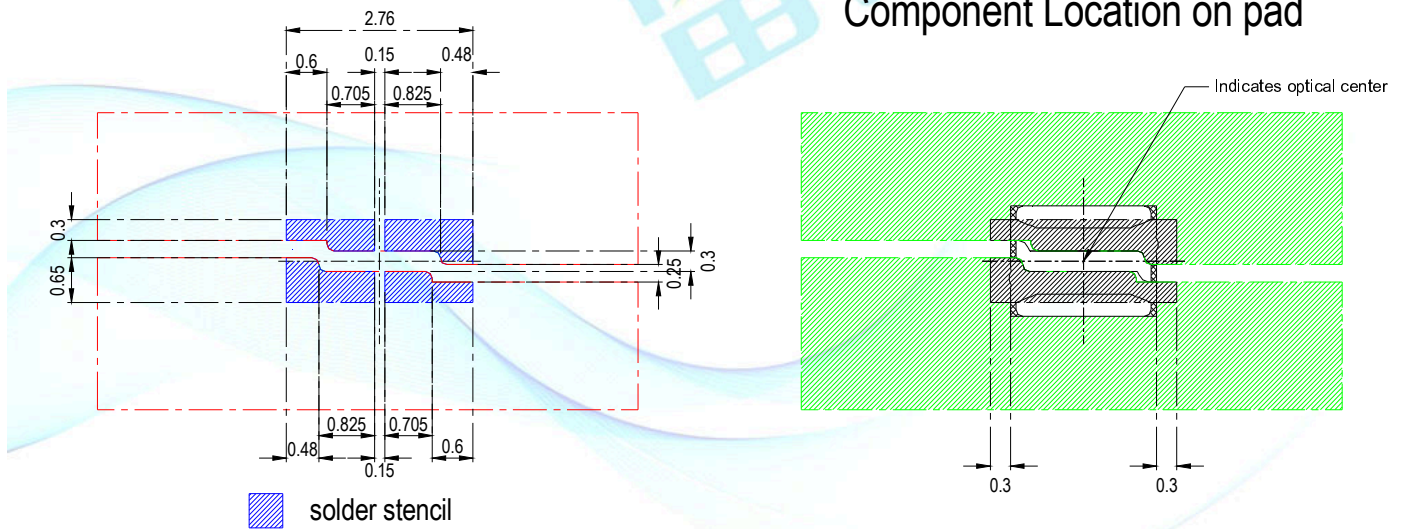

Note:  
Tolerance unless mentioned is  $\pm 0.05\text{mm}$ , Unit = mm.

## Applications

- Flash lights
- General lighting
- Decorative and Entertainment Lighting
- Indicators
- Illumination
- Automotive Telecommunication
- Switch lights

## Absolute Maximum Ratings (T<sub>Soldering</sub>=25°C)

Parameter	Symbol	Rating	Unit
Forward Current	I <sub>F</sub>	500	mA
Peak Forward Current (T=4.0s, tp=0.4s)	I <sub>FP</sub>	1600	mA
Power Dissipation	P <sub>d</sub>	5.7	W
Electrostatic Discharge(HBM)	ESD	8000	V
Thermal Resistance (junction to case)	R <sub>s</sub>	12	°C/W
Junction Temperature	T <sub>j</sub>	130	°C
Operating Temperature	T <sub>opr</sub>	-40 ~ +85	°C
Storage Temperature	T <sub>stg</sub>	-40 ~ +100	°C
Soldering Temperature	T <sub>sol</sub>	Reflow Soldering : 260 °C for 10 sec. Hand Soldering : 350 °C for 3 sec.	
Reverse Voltage	V <sub>R</sub>	5	V

**Electro-Optical Characteristics (T<sub>Soldering</sub>=25°C)**

Parameter	Symbol	Min.	Typ.	Max.	Unit	Condition
Luminous Flux	Φ	110	140	-----	lm	I <sub>F</sub> =500mA
Luminous Flux* <sup>3</sup>	Φ	200	240	300	lm	I <sub>FP</sub> =1000mA
Luminous Flux* <sup>3</sup>	Φ	215	270	-----	lm	I <sub>FP</sub> =1200mA
Luminous Flux* <sup>3</sup>	Φ	230	300	-----		I <sub>FP</sub> =1600mA
Luminance* <sup>3</sup> (At 1 meter of center)	E	75	90	-----	lux	I <sub>FP</sub> =1000mA
Luminance* <sup>3</sup> (At 1 meter of center)	E	85	103	-----	lux	I <sub>FP</sub> =1200mA
Luminance* <sup>3</sup> (At 1 meter of center)	E	95	116	-----	lux	I <sub>FP</sub> =1600mA
Forward Voltage	V <sub>F</sub>	2.55	3.00	3.50	V	I <sub>F</sub> =500mA
Forward Voltage* <sup>3</sup>	V <sub>F</sub>	2.75	3.20	3.65	V	I <sub>FP</sub> =1000mA
Forward Voltage* <sup>3</sup>	V <sub>F</sub>	2.80	3.25	-----	V	I <sub>FP</sub> =1200mA
Forward Voltage* <sup>3</sup>	V <sub>F</sub>	2.90	3.45	-----		I <sub>FP</sub> =1600mA
CRI	-----	65	70	-----		I <sub>FP</sub> =1000mA
Viewing Angle	2θ <sub>1/2</sub>	-----	120	-----	deg	I <sub>F</sub> =500mA
Reverse Current	I <sub>R</sub>	-----	-----	1	μA	V <sub>R</sub> =5V

**Bin Code Description**

Bin Range of Luminous Flux

Bin Code	Min.	Max.	Unit	Condition
L60	200	220	lm	I <sub>FP</sub> =1000mA
L61	220	260		
L62	260	300		

Bin Range of Forward Voltage

Bin Code	Min.	Max.	Unit	Condition
5	2.75	3.05	V	I <sub>FP</sub> =1000mA
6	3.05	3.35		
7	3.35	3.65		

Notes:

1. The value is based on driving current by 1000mA@50 ms pulse condition.
2. Tolerance of Luminous Flux: ±10%.
3. Tolerance of Forward Voltage : ±0.1V.

Bin Range of Chromaticity Coordinates

Bin Code	CIE_x	CIE_y
F	0.4680	0.3990
	0.4960	0.4440
	0.5650	0.4590
	0.5280	0.4150

Notes:

1. The value is based on driving current by 1000mA@50 ms pulse condition.
2. Tolerance of Chromaticity Coordinates:  $\pm 0.01$ .

The C.I.E. 1931 Chromaticity Diagram

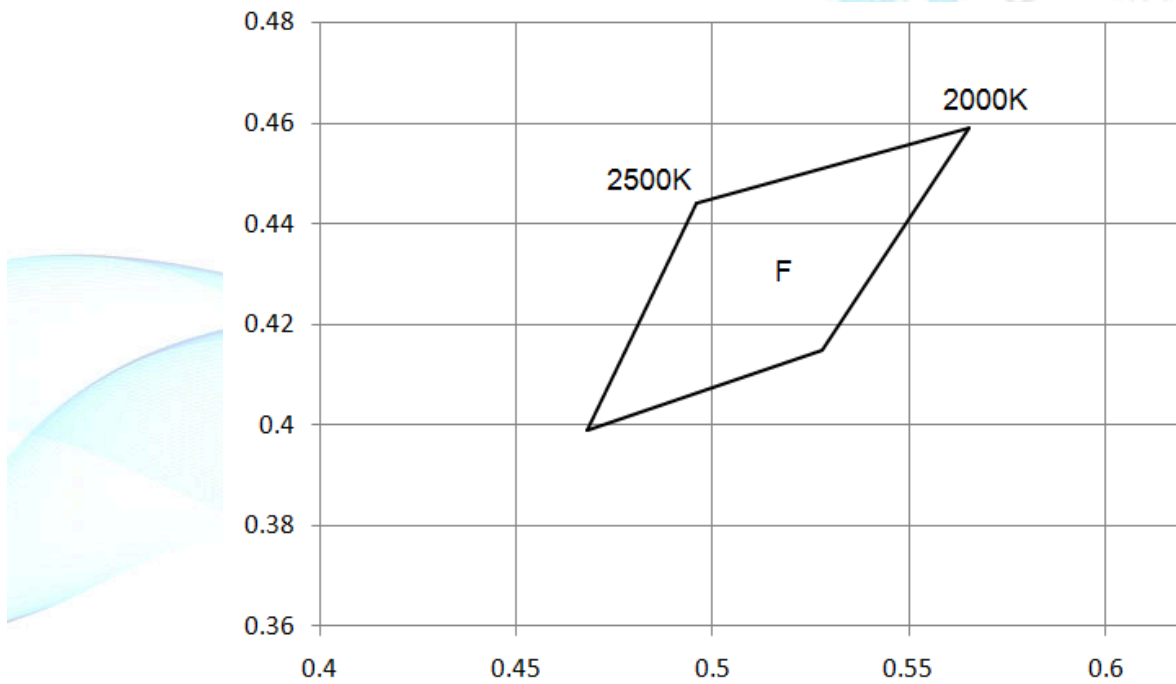

**Typical Electro-Optical Characteristics Curves**

Fig.1-Forward Current(I) vs. Forward Voltage  $T_s=25\text{ C}$

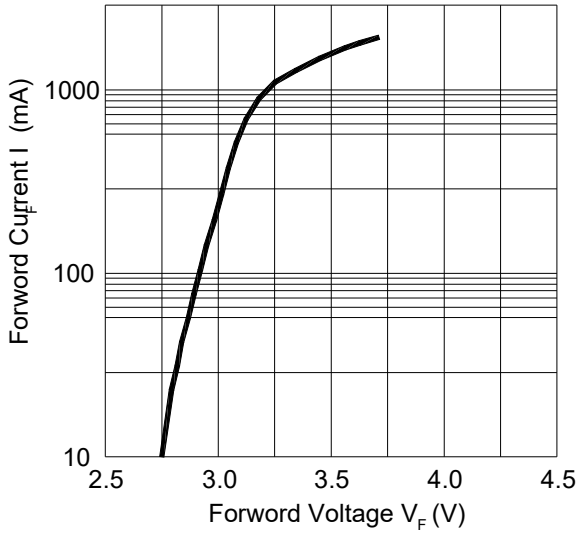

Fig.2-Relative Luminous Flux vs. Forward Current  $T_s=25\text{ C}$

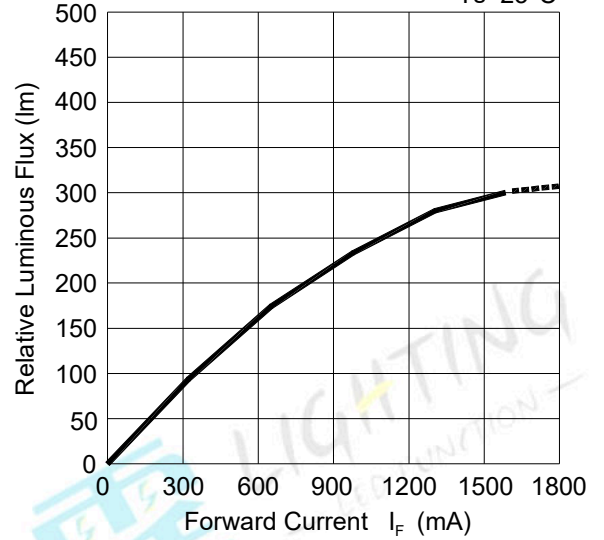

Fig.3-Max. Driving Forward Current vs. Soldering Temperature

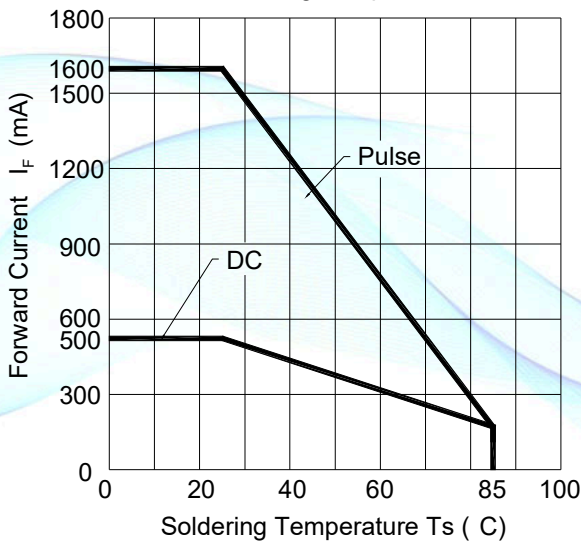
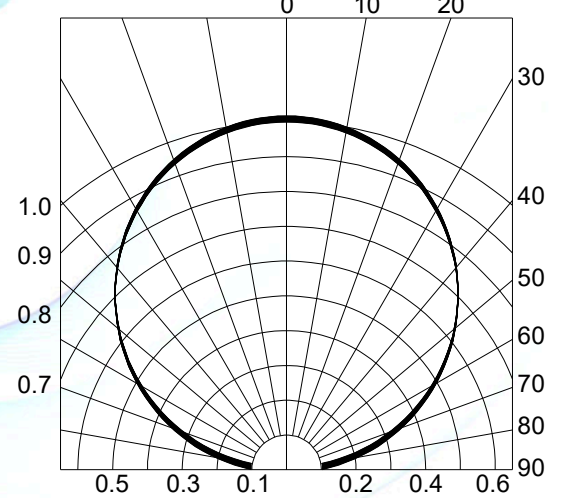

Fig.4-Radiation Diagram  $T_a=25\text{ C}$



**Typical Electro-Optical Characteristics Curves**

Fig.5-Forward Voltage Shift vs. Junction Temperature

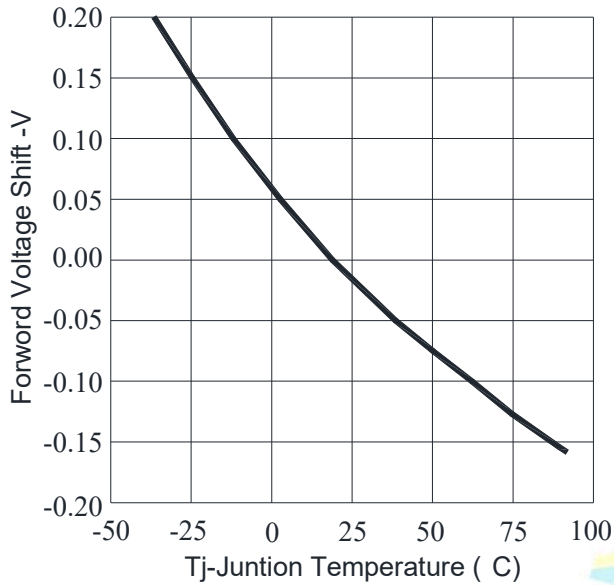
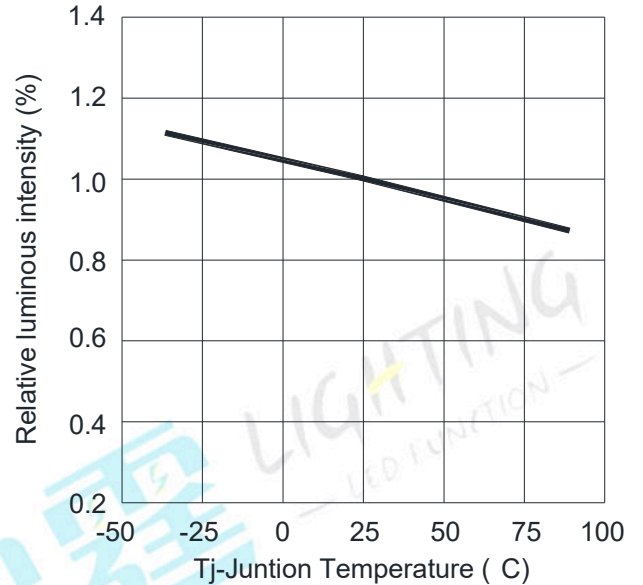
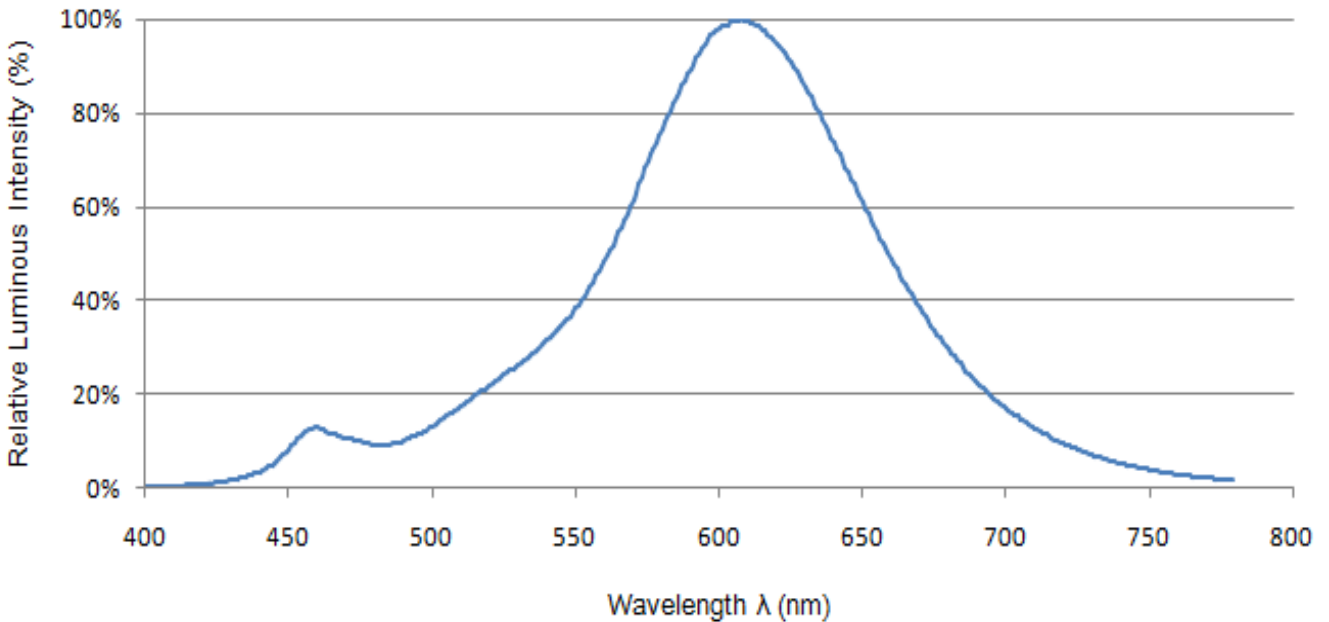

Fig.6-Relative Luminous Flux vs. Junction Temperature



**Spectrum Distribution**





**Moisture Resistant Packing Materials**

**Label Explanation**

**雷霆 LIGHTING**  
— LED FUNCTION —

P/N: ××××××××××  
TYPE: LXXXXXXXX-XXXX

	CODE	MIN	MAX	
IV:	××	××	××	lm
HUE:	××	××	××	
VF:	××	××	××	v
QTY:	××××			
LOT NO.:	××××××××××			

QR code: [QR Code]

Pb-Free, RoHS

- \* QR code:  
Contains all of the following information
- \* P/N: Product Number
- \* TYPE :Part NO.
- \* IV: Luminous Flux Rank
- \* HUE: Chromaticity Coordinates Rank
- \* VF: Forward Voltage Rank
- \* QTY: Packing Quantity
- \* LOT NO.: Lot Number

**Taping method: Loaded Quantity 4,000 pcs Per Reel**

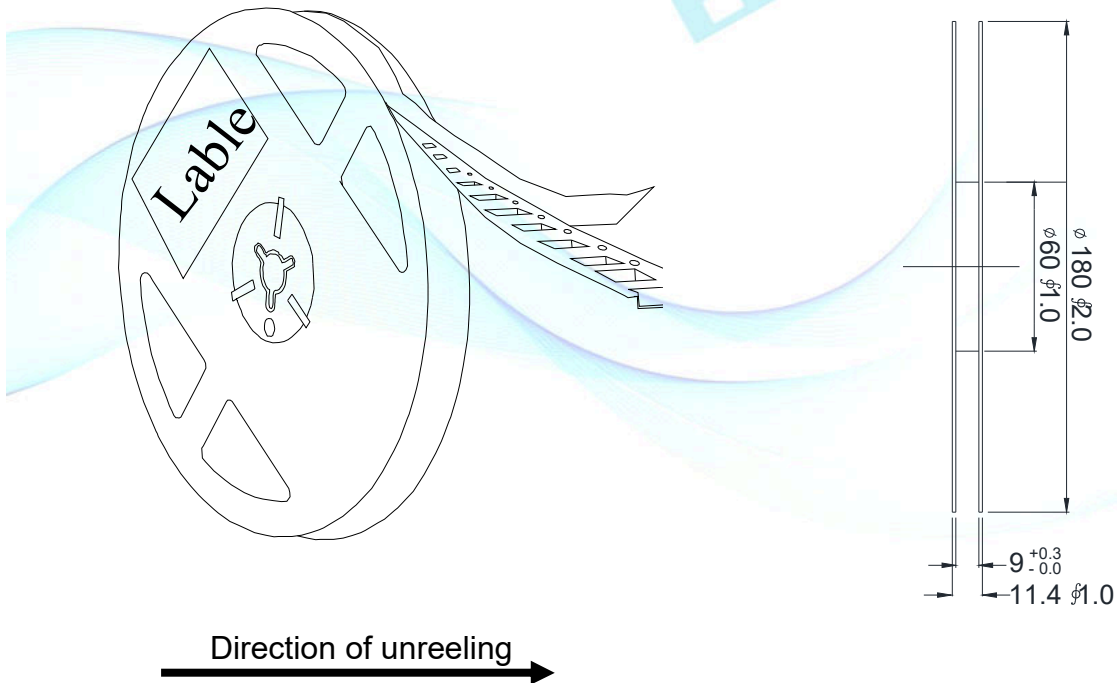

- Notes:
1. Tolerance unless mentioned is  $\pm 0.1$ mm, Unit = mm.
  2. Minimum packing amount is 1000 pcs per reel.

**Carrier Tape Dimensions:**

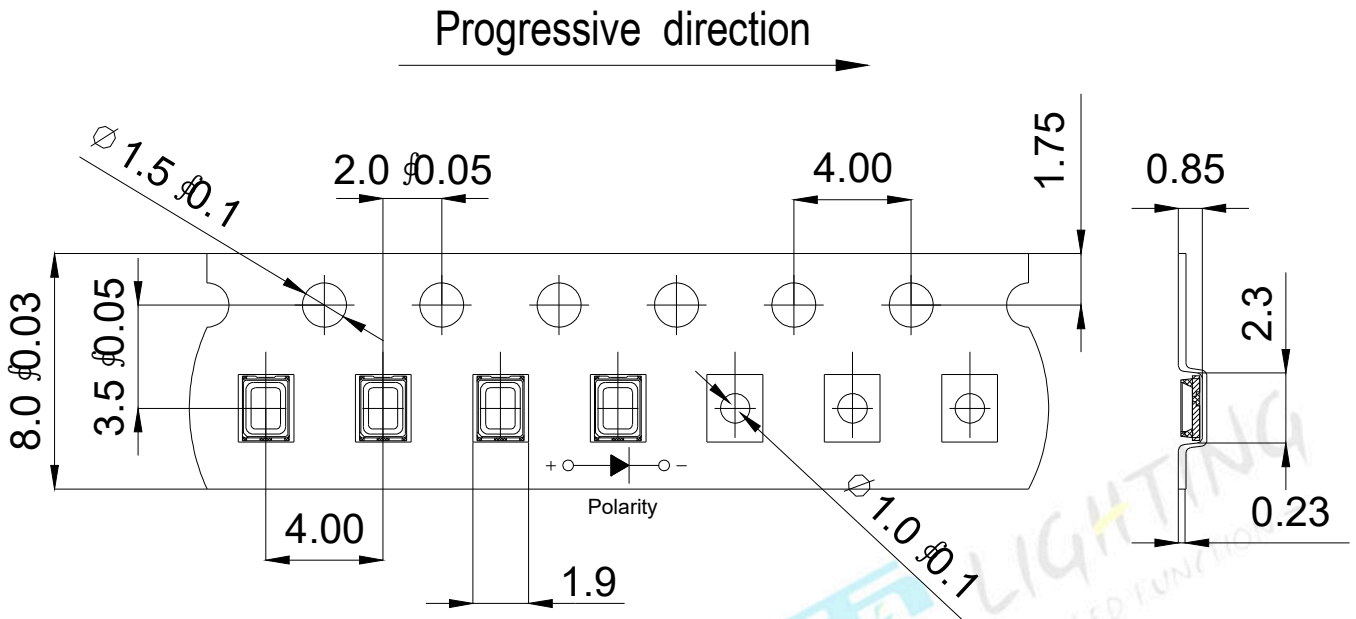

Note:  
Tolerance unless mentioned is  $\pm 0.1$ mm, Unit = mm.

**Moisture Resistant Packing Process**

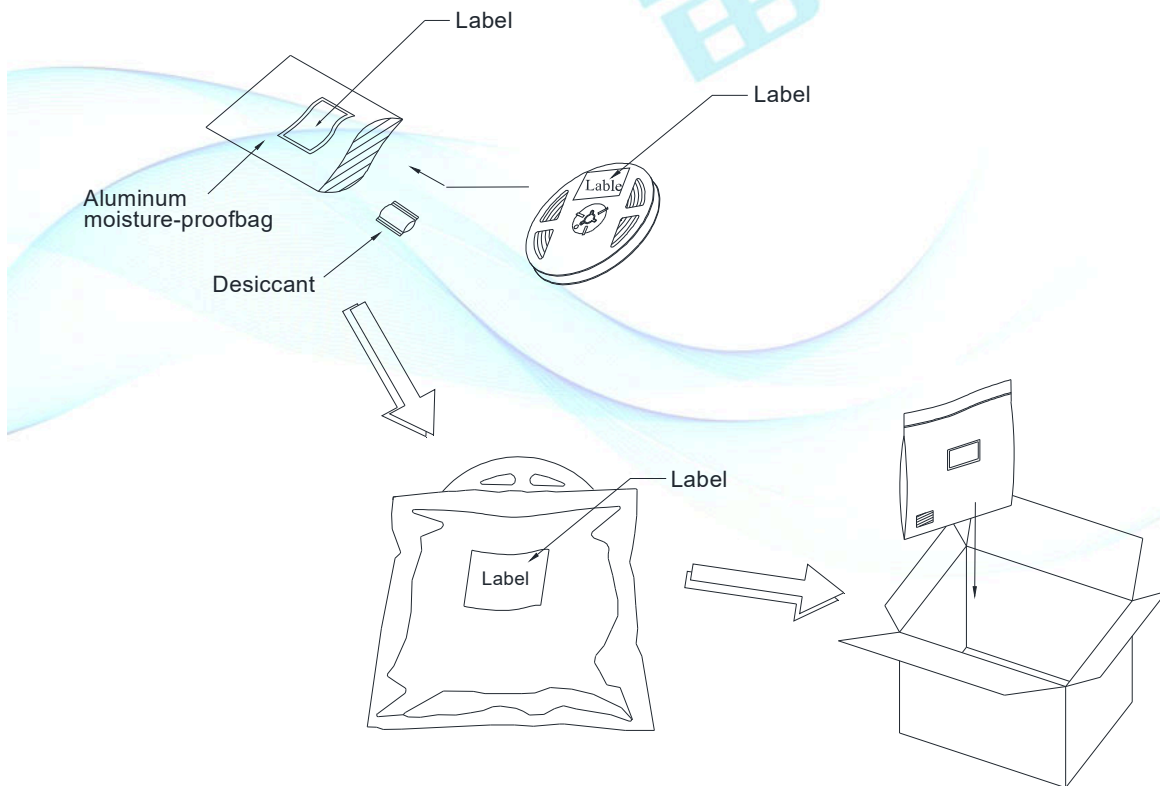

Moisture/Reflow sensitivity classification  
IPC / JEDEC J-STD-020C: Level 3

**Reliability Test Items and Conditions**

The reliability of products shall be satisfied with items listed below.

Confidence level : 90%

LTPD : 10%

No.	Items	Test Condition	Test Hours/Cycles	Sample Size	Ac/Re
1	Reflow Soldering	Temp.: 260°C/10sec.	6 Min.	22 PCS.	0/1
2	Thermal Shock	H : +100°C/5min ∫ 10 sec L : -10°C/5min	300 Cycles	22 PCS.	0/1
3	Temperature Cycle	H : +100°C/15min ∫ 5 min L : -40°C/15min	300 Cycles	22 PCS.	0/1
4	High Temperature/Humidity Storage	Ta=85°C,85%RH	1000 Hrs.	22 PCS.	0/1
5	Low Temperature Storage	Ta=-40°C	1000 Hrs.	22 PCS.	0/1
6	High Temperature Storage	Ta=100°C	1000 Hrs.	22 PCS.	0/1
7	DC Operation Life	Ta=25°C, I <sub>F</sub> = 500 mA	1000 Hrs.	22 PCS.	0/1
8	Peak Forward Current Operation Life ( T=4.0s, tp=0.4s)	Ta=25°C, I <sub>FP</sub> = 1600 mA	100000 cycles	5 PCS	0/1

Note:

All reliability items are tested under good thermal management with 1.0 x 1.0 cm<sup>2</sup> MCPCB

## Precautions for Use

1. Over-current-proof  
Customer must apply resistors for protection; otherwise slight voltage shift will cause big current change (Burn out will happen).
2. Storage
  - 2.1 Do not open moisture proof bag before the products are ready to use.
  - 2.2 Before opening the package: The LEDs should be kept at 30°C or less and 90%RH or less.
  - 2.3 After opening the package: The LED's floor life is 168 Hrs. under 30°C or less and 60%RH or less. If unused LEDs remain, it should be stored in moisture proof packages.
  - 2.4 If the moisture absorbent material (silica gel) has faded away or the LEDs have exceeded the storage time, baking treatment should be performed using the following conditions.  
Baking treatment: 60±5°C for 24 hours.
3. Soldering Condition
  - 3.1 Pb-free solder temperature profile

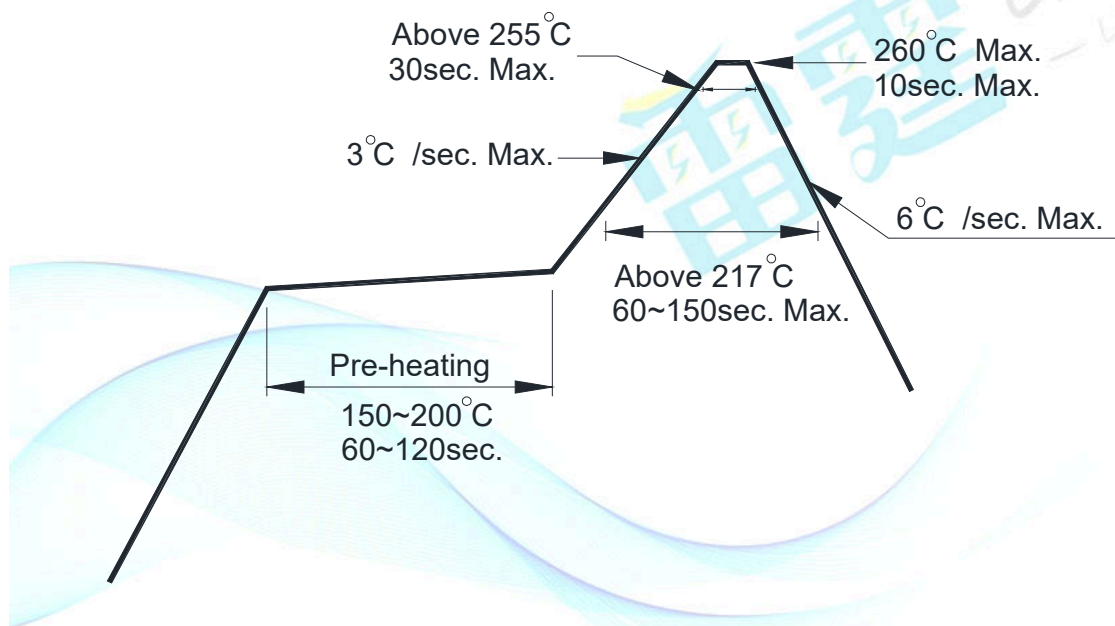

- 3.2 Reflow soldering should not be done more than two times.
- 3.3 When soldering, do not put stress on the LEDs during heating.
- 3.4 After soldering, do not warp the circuit board.

## 4. Soldering Iron

Each terminal is to go to the tip of soldering iron temperature less than 350°C for 3 seconds within once in less than the soldering iron capacity 25W. Leave two seconds and more intervals and do soldering of each terminal. Be careful because the damage of the product is often started at the time of the hand solder.

## 5. Repairing

Repair should not be done after the LEDs have been soldered. When repairing is unavoidable, a double-head soldering iron should be used (as below figure). It should be confirmed beforehand whether the characteristics of the LEDs will or will not be damaged by repairing.