

Customer Approved
Date:

Part No.:
LB153IR1C-A02D2

DATA SHEET

Issue Date: 2018.05.16
Issue No.: LTD-153IR-003
REVISION: V2

Designer	Checker	Approver
<i>Vic</i>	<i>Rock</i>	<i>Jeff</i>

SMD Type ■ Top view 1206 Lens Package
LB153IR1C-A02D2

Features

- 1206 Lens package
- Top view LED
- Compatible with infrared and vapor phase reflow solder process
- Narrow viewing angle
- Pb-free
- RoHS compliant

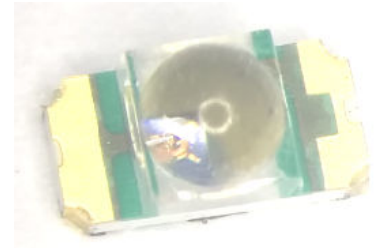

Package Dimensions

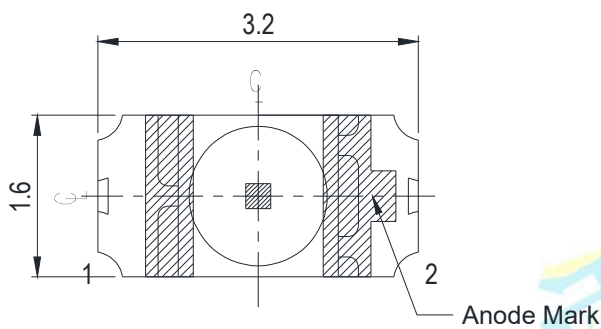

Polarity

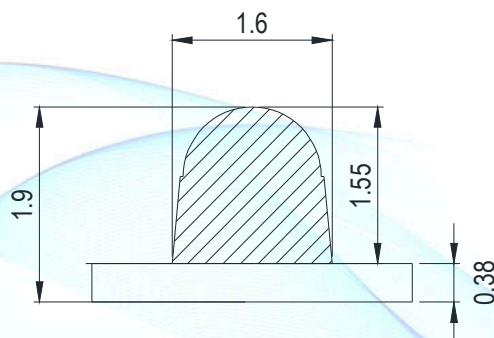

Recommended Solder Pad

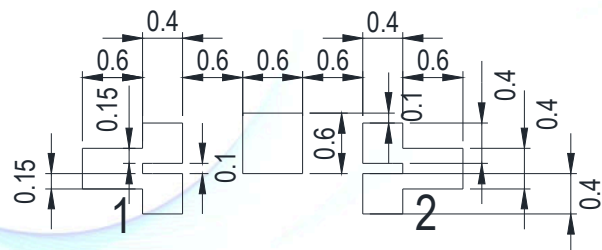

Component Location on pad

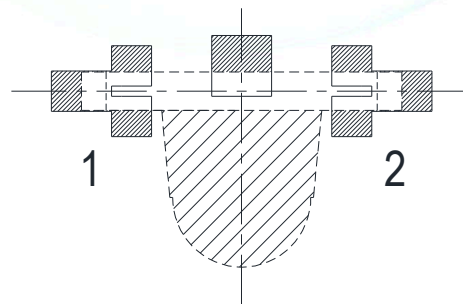
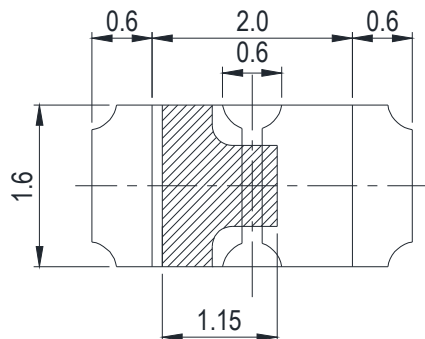

Note:
Tolerance unless mentioned is ± 0.1 mm, Unit = mm.

Applications

- Free air transmission system
- Infrared remote control units with high power requirement
- Smoke detector
- Infrared applied system

Absolute Maximum Ratings (T_{Soldering}=25°C)

Parameter	Symbol	Rating	Unit
Forward Current	I _F	100	mA
Peak Forward Current Pulse Width ≤ 100μs ,Duty ≤ 1%.	I _{FP}	1.0	A
Power Dissipation	P _d	130	mW
Operating Temperature	T _{opr}	-40 ~ +85	°C
Storage Temperature	T _{stg}	-40 ~ +100	°C
Soldering Temperature	T _{sol}	Reflow Soldering : 260°C for 10 sec. Hand Soldering : 350°C for 3 sec.	
Reverse Voltage	V _R	5	V

Electro-Optical Characteristics (T_{Soldering}=25°C)

Parameter	Symbol	Min.	Typ.	Max.	Unit	Condition
Radiant Intensity	E _e	14	-	36	mW/sr	I _F =20mA
Radiant Intensity	E _e	-	125	-	mW/sr	I _F =100mA Pulse Width ≤ 100μs , Duty ≤ 10%
Forward Voltage	V _F	1.2	-	1.6	V	I _F =20mA
Forward Voltage	V _F	-	1.8	2.4	V	I _F =100mA Pulse Width ≤ 100μs , Duty ≤ 10%
Peak Wavelength	λ _D	-	940	-	nm	I _F =20mA
Viewing Angle	2θ _{1/2}	-	15	-	deg	I _F =20mA
Reverse Current	I _R	-	-	10	μA	V _R =5V

Notes:

- 1.Tolerance of Luminous Intensity ±10%.
- 2.Tolerance of Dominant Wavelength : ±1nm.
- 3.Tolerance of Forward Voltage : ±0.05V.

Bin Code Description

Bin Range of Radiant Intensity

Bin Code	Min.	Max.	Unit	Condition
A12	14	16	mW/sr	I _F =20mA
A13	16	20		
A14	20	24		
A15	24	30		
A16	30	36		

Bin Range of Forward Voltage

Bin Code	Min.	Max.	Unit	Condition
19	1.2	1.3	V	I _F =20mA
20	1.3	1.4		
21	1.4	1.5		
22	1.5	1.6		

Notes:

- 1.Tolerance of Radiant Intensity $\pm 10\%$.
- 2.Tolerance of Forward Voltage : $\pm 0.05V$.

Typical Electro-Optical Characteristics Curves

Fig.1-Forward Current vs. Forward Voltage $T_a=25^\circ\text{C}$

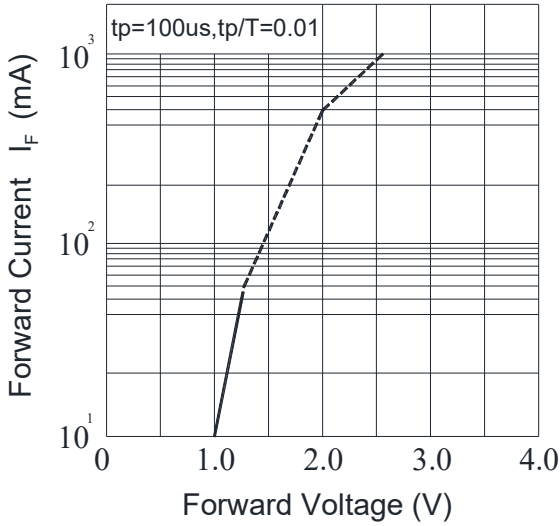

Fig.2-Relative Intensity vs. Forward Current

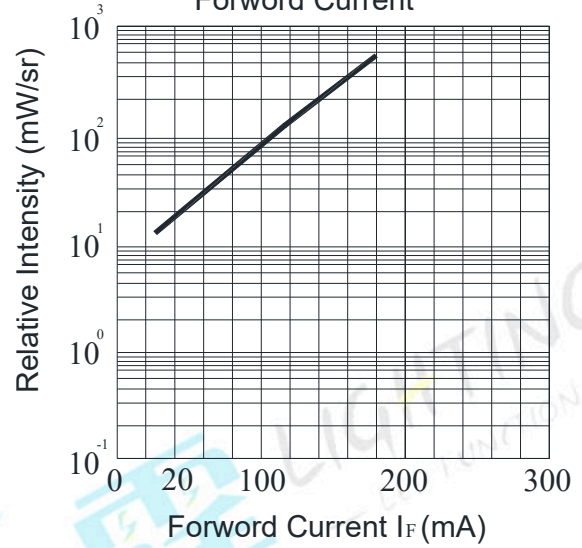

Fig.3-Forward Current vs. Ambient Temperature

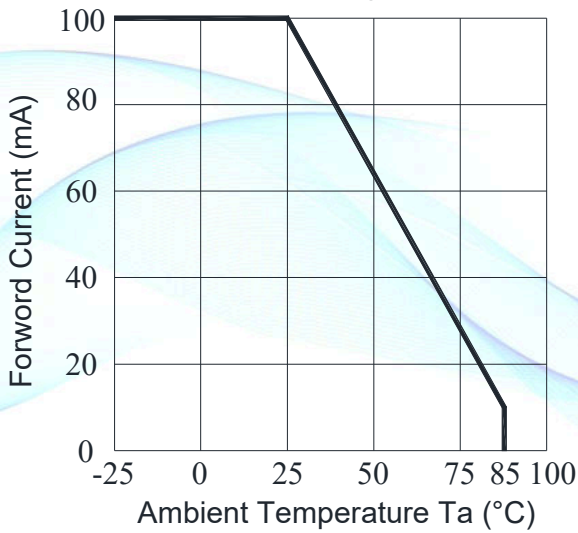
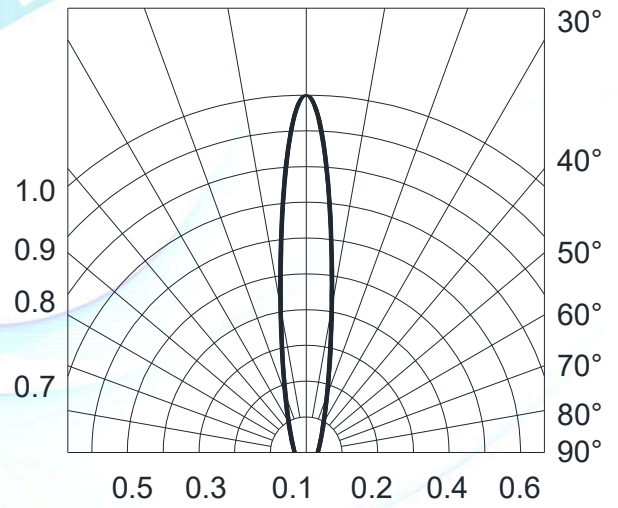

Fig.4-Radiation Diagram $T_a=25^\circ\text{C}$



Typical Electro-Optical Characteristics Curves

Fig.5-Peak Emission Wavelength vs. Ambient Temperature

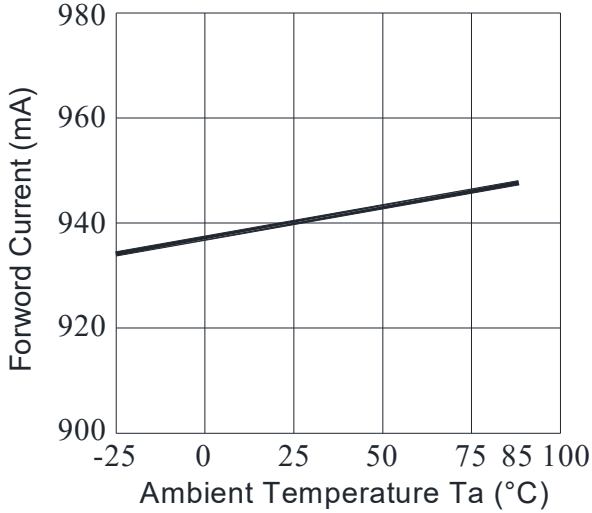

Fig.6-Spectral Sensitivity

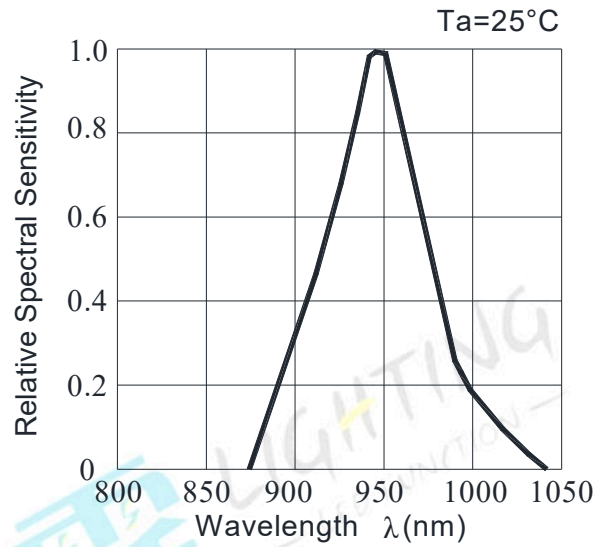

Fig.7-Relative Intensity vs. Ambient Temperature Ta=25°C

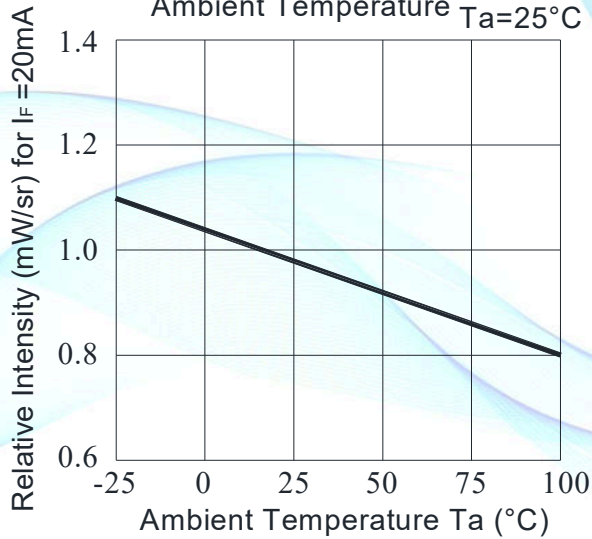
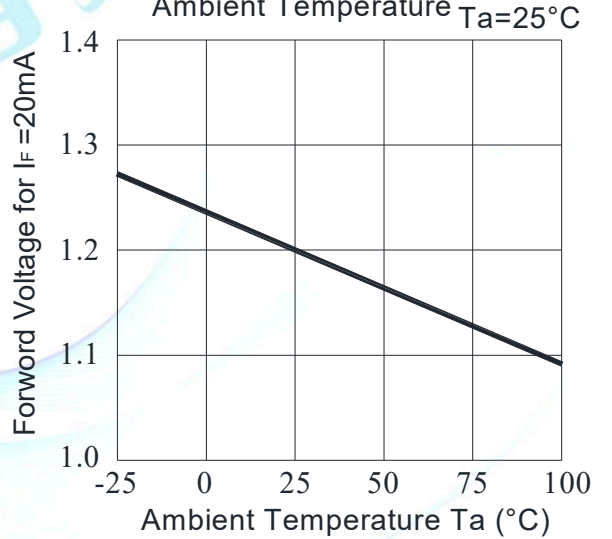

Fig.8-Forward Voltage vs. Ambient Temperature Ta=25°C



Moisture Resistant Packing Materials

Label Explanation





雷霆 LIGHTING
— LED FUNCTION —

P/N: ××××××××××
 TYPE: L×××××××-××××

	CODE	MIN	MAX	
IV:	××	××	××	mW
HUE:	××	××	××	
VF:	××	××	××	V
QYT:	××××			
LOT NO.:	××××××××××			

- * QR code:
Contains all of the following information
- * P/N: Product Number
- * TYPE :Part NO.
- * IV: Radiant Intensity Rank
- * HUE: Dom. Wavelength Rank
- * VF: Forward Voltage Rank
- * QTY: Packing Quantity
- * LOT NO.: Lot Number

Taping method: Loaded Quantity 2,000 pcs Per Reel

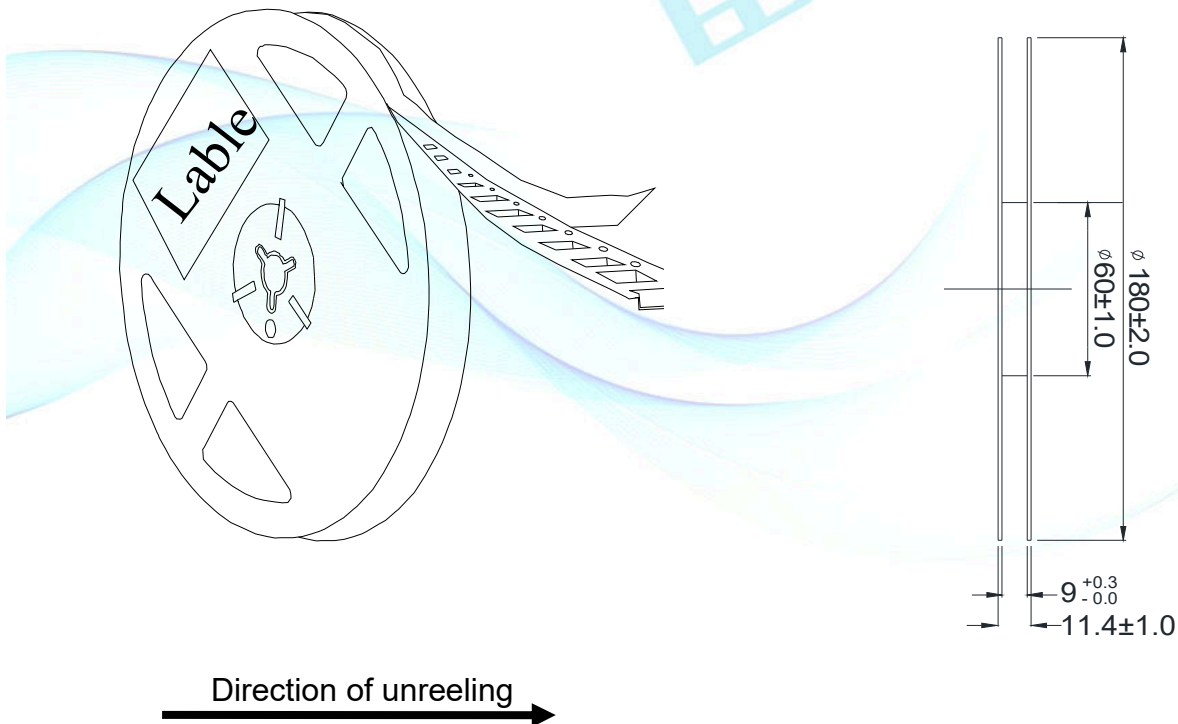

- Notes:
1. Tolerance unless mentioned is ±0.1mm, Unit = mm.
 2. Minimum packing amount is 1000 pcs per reel.

Carrier Tape Dimensions:

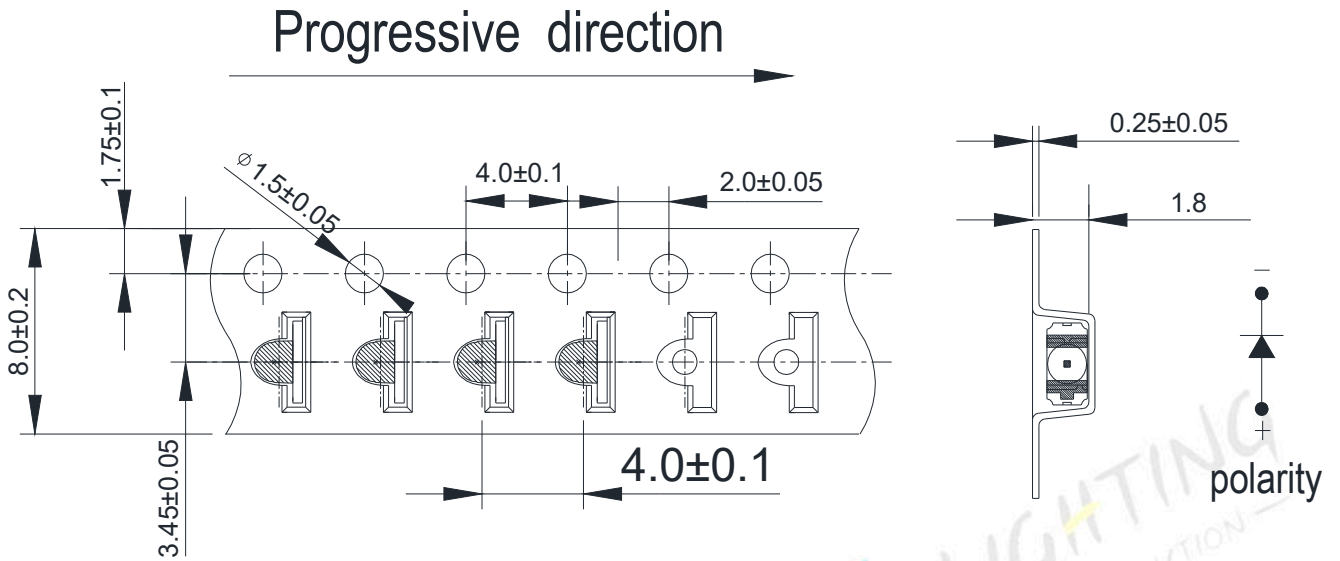

Note:
Tolerance unless mentioned is ± 0.1 mm, Unit = mm.

Moisture Resistant Packing Process

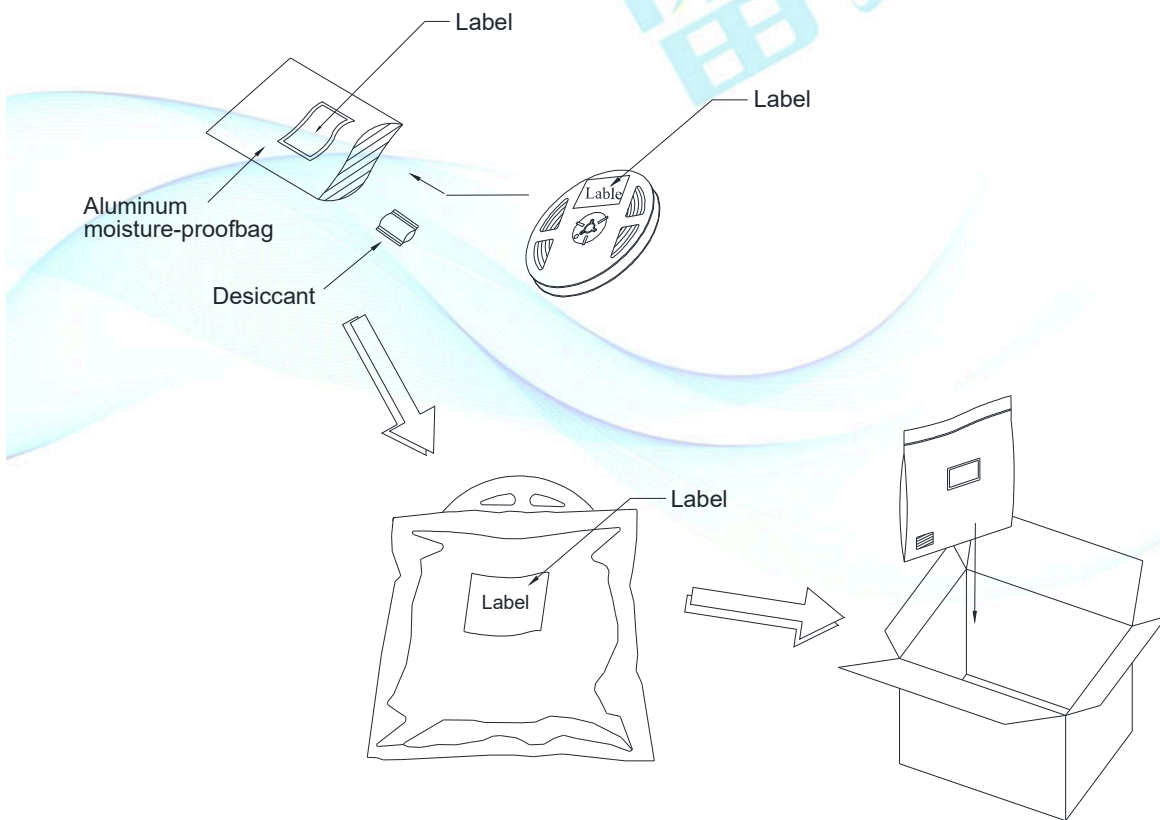

Moisture/Reflow sensitivity classification
IPC / JEDEC J-STD-020C: Level 2

Reliability Test Items and Conditions

The reliability of products shall be satisfied with items listed below.

Confidence level : 90%

LTPD : 10%

No.	Items	Test Condition	Test Hours/Cycles	Sample Size	Ac/Re
1	Reflow Soldering	Temp.: 260°C/10sec.	6 Min.	22 PCS.	0/1
2	Thermal Shock	H : +100°C/5min ∫ 10 sec L : -10°C/5min	300 Cycles	22 PCS.	0/1
3	Temperature Cycle	H : +100°C/15min ∫ 5 min L : -40°C/15min	300 Cycles	22 PCS.	0/1
4	High Temperature/Humidity Storage	Ta=85°C,85%RH	1000 Hrs.	22 PCS.	0/1
5	Low Temperature Storage	Ta=-40°C	1000 Hrs.	22 PCS.	0/1
6	High Temperature Storage	Ta=100°C	1000 Hrs.	22 PCS.	0/1
7	DC Operation Life	Ta=25°C, I _F = 20 mA	1000 Hrs.	22 PCS.	0/1

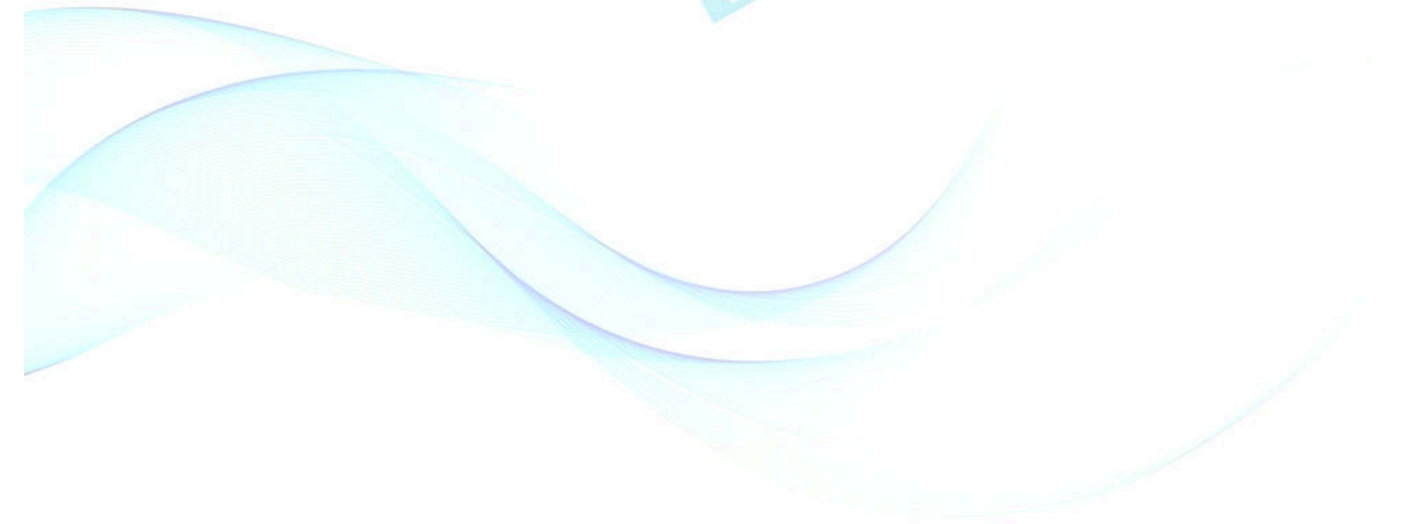

Precautions for Use

1. Over-current-proof

Customer must apply resistors for protection; otherwise slight voltage shift will cause big current change (Burn out will happen).

2. Storage

2.1 Do not open moisture proof bag before the products are ready to use.

2.2 Before opening the package: The LEDs should be kept at 30°C or less and 90%RH or less.

2.3 After opening the package: The LED's floor life is 1 year under 30°C or less and 60%RH or less. If unused LEDs remain, it should be stored in moisture proof packages.

2.4 If the moisture absorbent material (silica gel) has faded away or the LEDs have exceeded the storage time, baking treatment should be performed using the following conditions.

Baking treatment: 60±5°C for 24 hours.

3. Soldering Condition

3.1 Pb-free solder temperature profile

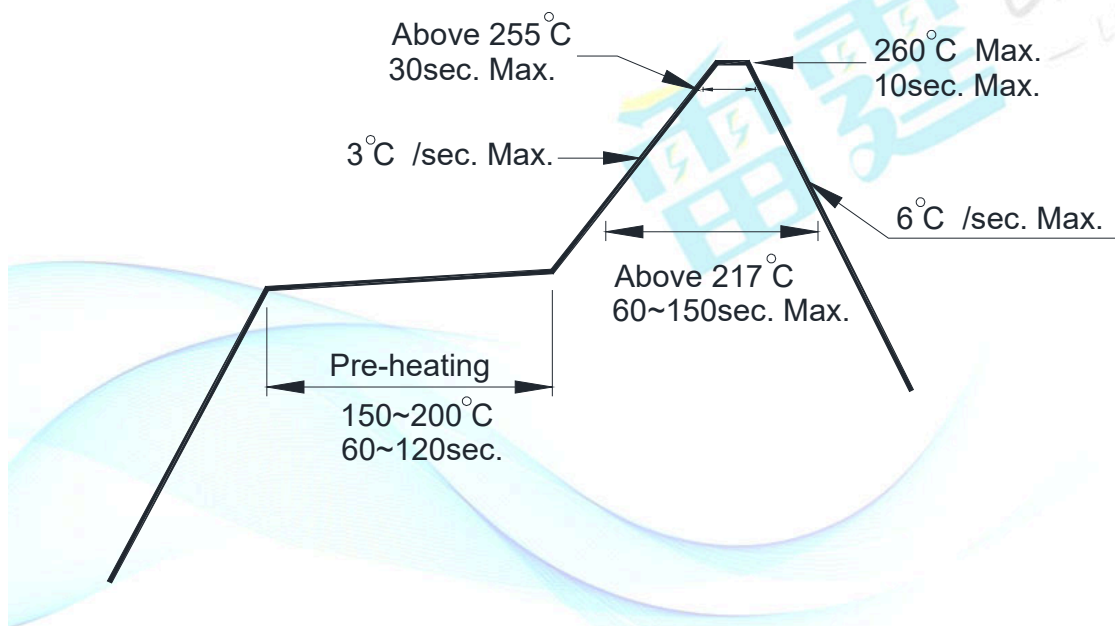

3.2 Reflow soldering should not be done more than two times.

3.3 When soldering, do not put stress on the LEDs during heating.

3.4 After soldering, do not warp the circuit board.

4. Soldering Iron

Each terminal is to go to the tip of soldering iron temperature less than 350°C for 3 seconds within once in less than the soldering iron capacity 25W. Leave two seconds and more intervals and do soldering of each terminal. Be careful because the damage of the product is often started at the time of the hand solder.

5. Repairing

Repair should not be done after the LEDs have been soldered. When repairing is unavoidable, a double-head soldering iron should be used (as below figure). It should be confirmed beforehand whether the characteristics of the LEDs will or will not be damaged by repairing.