

<b>Customer Approved</b>
<b>Date:</b>

**Part No.:**  
**LL820IR3C-A02T4**

**DATA SHEET**

Issue Date: 2019.01.31  
Issue No.: LTD-820-010  
REVISION: V1

Designer	Checker	Approver
<i>Lisa</i>	<i>Rock</i>	<i>Allen</i>

## Infrared LED Type ■ Top view 2016 Package LL820IR3C-A02T4

### Features

- 2016 package
- Top view LED
- Compatible with infrared and vapor phase reflow solder process
- Pb-free
- RoHS compliant



### Package Dimensions

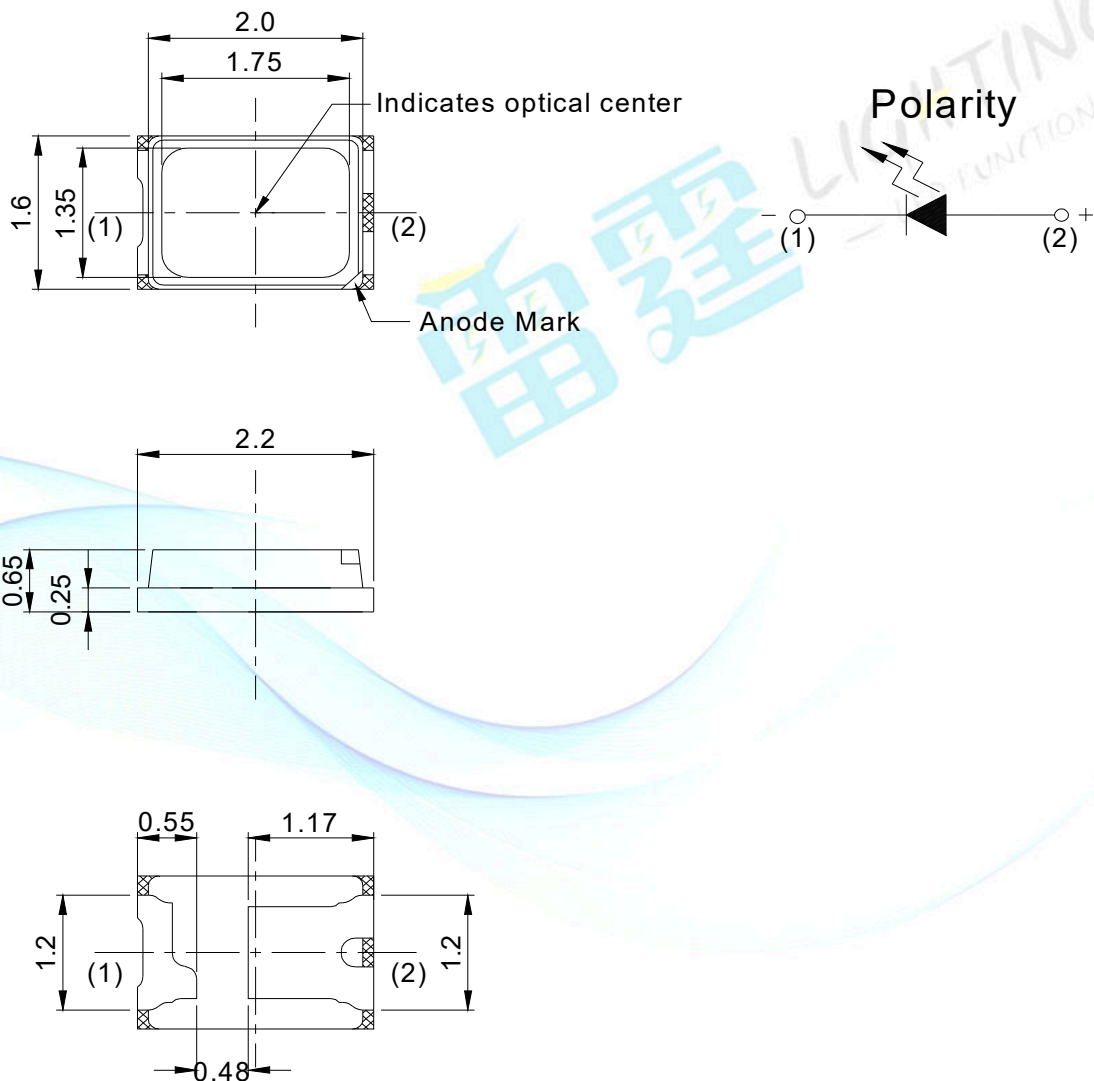

Note:  
Tolerance unless mentioned is  $\pm 0.1$ mm, Unit = mm.

**Recommended Solder Pad**

**Compatible Design**

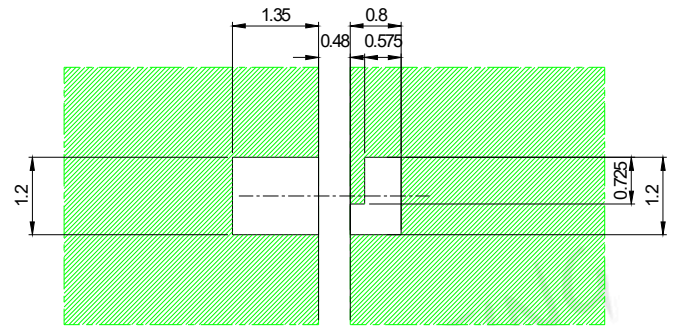
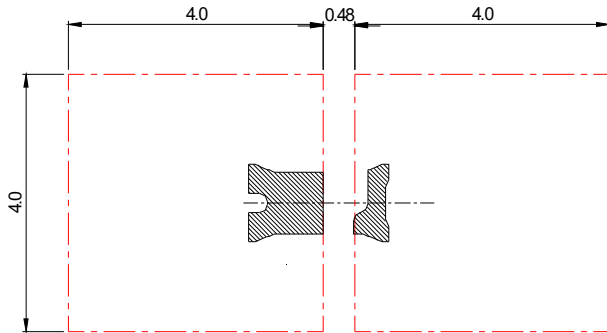

■ foot print □ Cu area (Min: 16 mm<sup>2</sup>)  
(Cu plating layer Min: 15 um)

■ solder resist

**Component Location on pad**

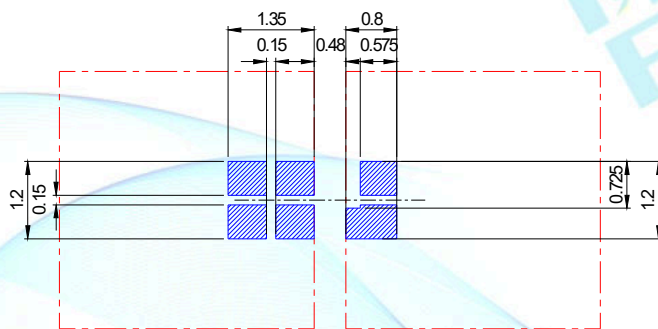

■ solder stencil

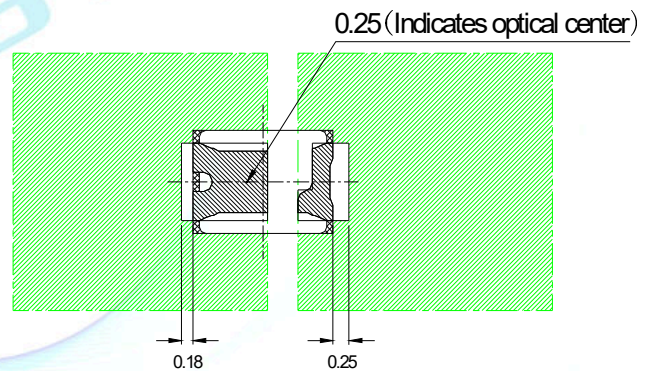

Note:  
Tolerance unless mentioned is  $\pm 0.05\text{mm}$ , Unit = mm.

### Applications

- Free air transmission system
- Infrared remote control units with high power requirement
- Smoke detector
- Infrared applied system

### Device Selection Guide

Emitted Color	Resin Color
Infrared	Water Clear

### Absolute Maximum Ratings (T<sub>Soldering</sub>=25°C)

Parameter	Symbol	Rating	Unit
Forward Current	I <sub>F</sub>	360	mA
Peak Forward Current (T=1.3s, tp=0.3s)	I <sub>FP</sub>	750	mA
Power Dissipation	P <sub>d</sub>	620	mW
Junction Temperature	T <sub>j</sub>	115	°C
Operating Temperature	T <sub>opr</sub>	-40 ~ +85	°C
Storage Temperature	T <sub>stg</sub>	-40 ~ +100	°C
Soldering Temperature	T <sub>sol</sub>	Reflow Soldering : 260°C for 10 sec. Hand Soldering : 350°C for 3 sec.	
Reverse Voltage	V <sub>R</sub>	5	V

**Note:**

The products are sensitive to static electricity and must be carefully taken when handling products.

**Electro-Optical Characteristics (T<sub>Soldering</sub>=25°C)**

Parameter	Symbol	Min.	Typ.	Max.	Unit	Condition
Radiant Intensity	E <sub>e</sub>	28	31	36	mw/sr	I <sub>F</sub> =200mA
Peak Wavelength	λ <sub>P</sub>	-----	850	-----	nm	I <sub>F</sub> =200mA
Forward Voltage	V <sub>F</sub>	1.3	1.6	1.9	V	I <sub>F</sub> =200mA
Viewing Angle	2θ <sub>1/2</sub>	-----	120	-----	deg	I <sub>F</sub> =200mA
Reverse Current	I <sub>R</sub>	-----	-----	10	μA	V <sub>R</sub> =5V

Notes:

- 1.Tolerance of Radiant Intensity ±10%.
- 2.Tolerance of Forward Voltage : ±0.1V

**Bin Code Description**

Bin Range of Radiant Intensity

Bin Code	Min.	Max.	Unit	Condition
A16	28	32	mw/sr	I <sub>F</sub> =200mA
A17	32	36		

Bin Range of Forward Voltage

Bin Code	Min.	Max.	Unit	Condition
V2	1.3	1.5	V	I <sub>F</sub> =200mA
V3	1.5	1.7		
V4	1.7	1.9		

Notes:

- 1.Tolerance of Luminous Intensity ±10%.
- 2.Tolerance of Forward Voltage : ±0.1V.

**Typical Electro-Optical Characteristics Curves**

Fig.1-Forward Current vs. Forward Voltage  $T_a=25^\circ\text{C}$

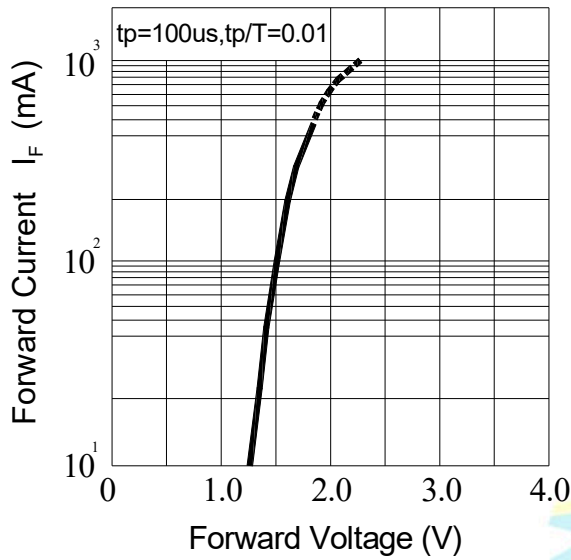

Fig.2-Relative Intensity vs. Forward Current

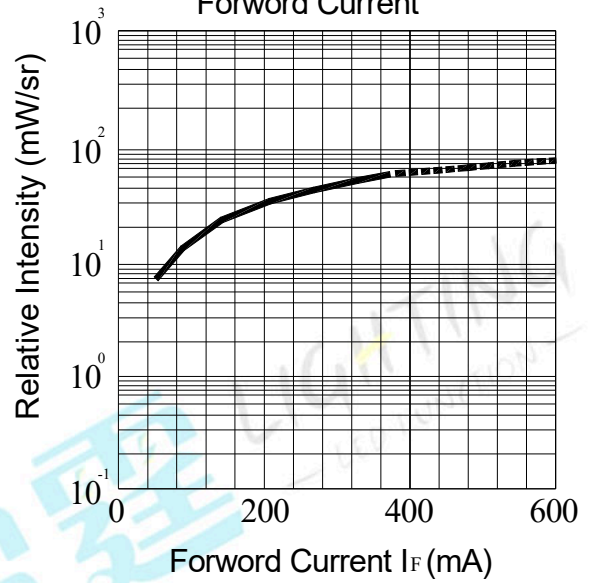

Fig.3-Forward Current vs. Ambient Temperature

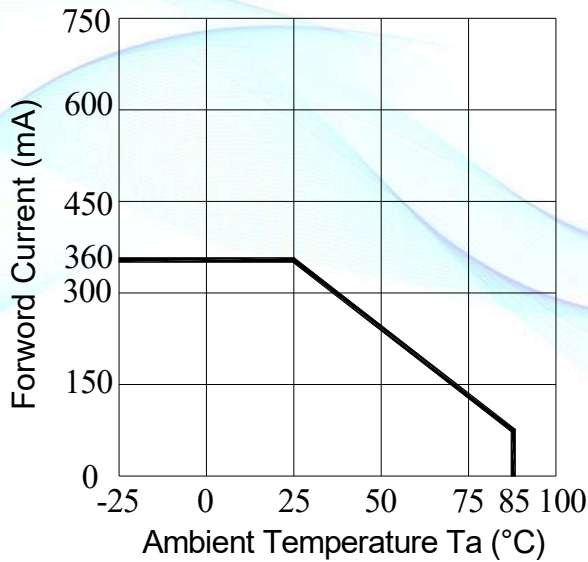
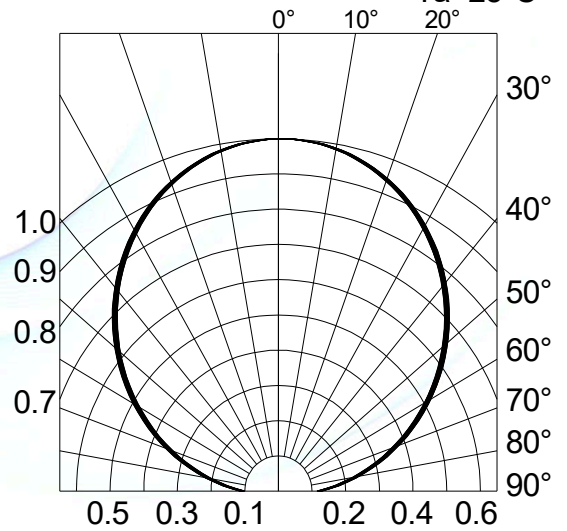

Fig.4-Radiation Diagram  $T_a=25^\circ\text{C}$



**Typical Electro-Optical Characteristics Curves**

Fig.5-Forward Voltage Shift vs. Junction Temperature

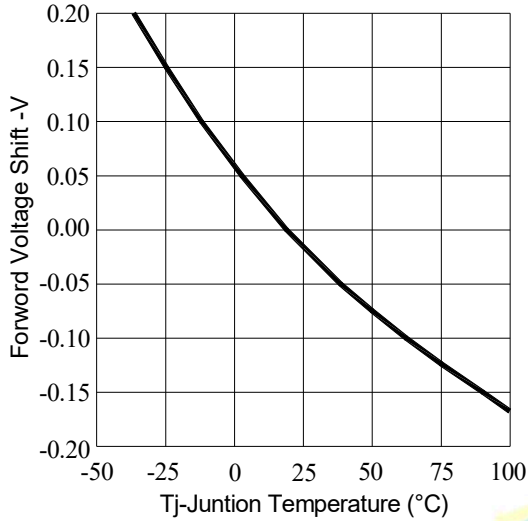
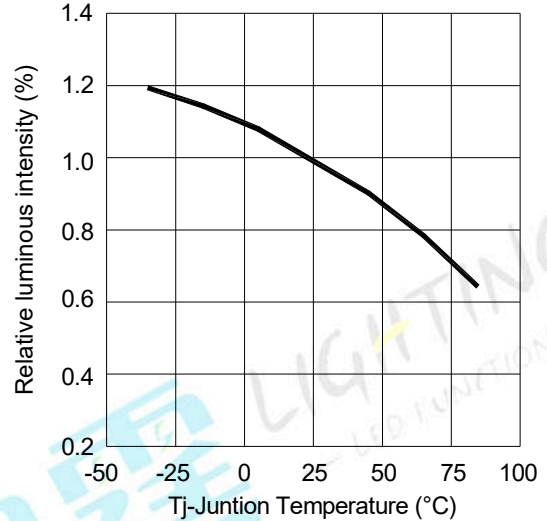
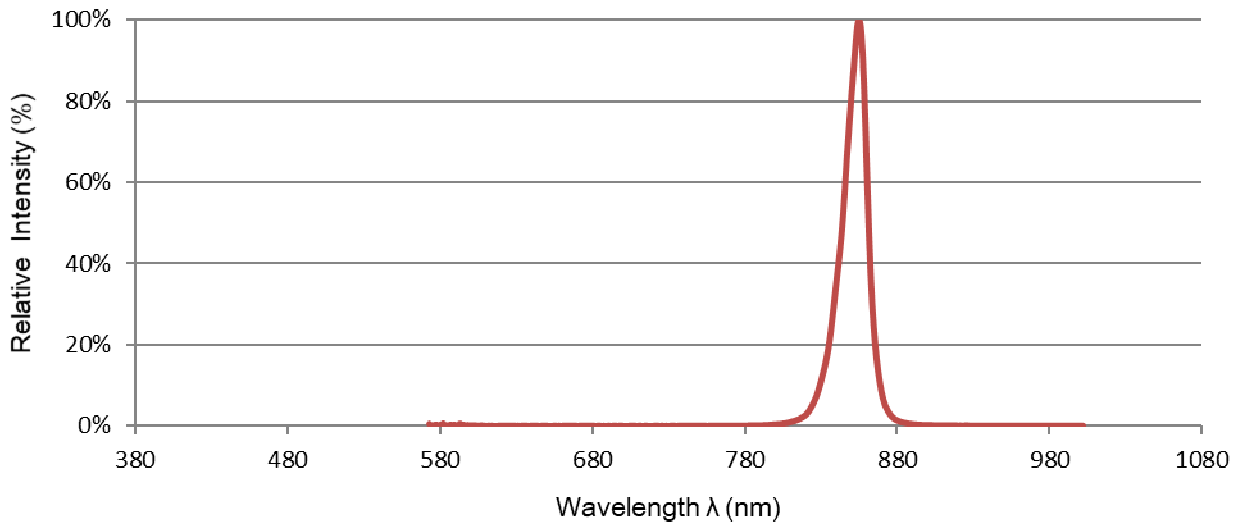

Fig.6-Relative Luminous Intensity vs. Junction Temperature



**Spectrum Distribution**



**Moisture Resistant Packing Materials  
Label Explanation**



- \* QR code:  
Contains all of the following information
- \* P/N: Product Number
- \* TYPE :Part NO.
- \* IV : Radiant Intensity Rank
- \* WD: Dom. Wavelength Rank
- \* VF: Forward Voltage Rank
- \* QTY: Packing Quantity
- \* LOT NO.: Lot Number

**Taping method: Loaded Quantity 4,000 pcs Per Reel**

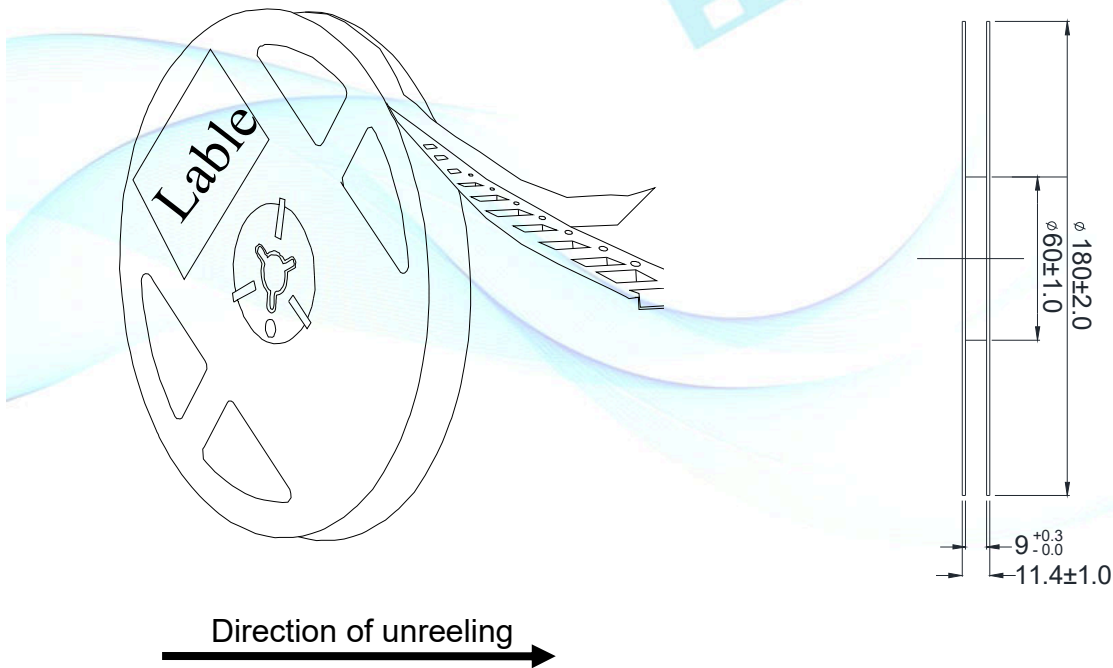

- Notes:
1. Tolerance unless mentioned is  $\pm 0.1$ mm, Unit = mm.
  2. Minimum packing amount is 1000 pcs per reel.



**Carrier Tape Dimensions:**

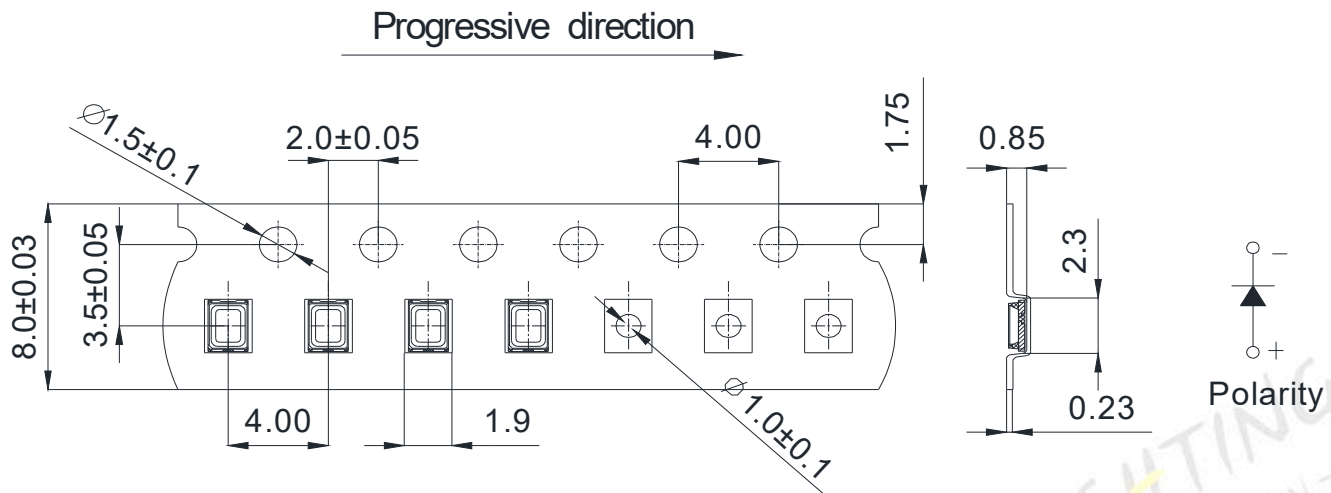

Note:  
Tolerance unless mentioned is  $\pm 0.1$ mm, Unit = mm.

**Moisture Resistant Packing Process**

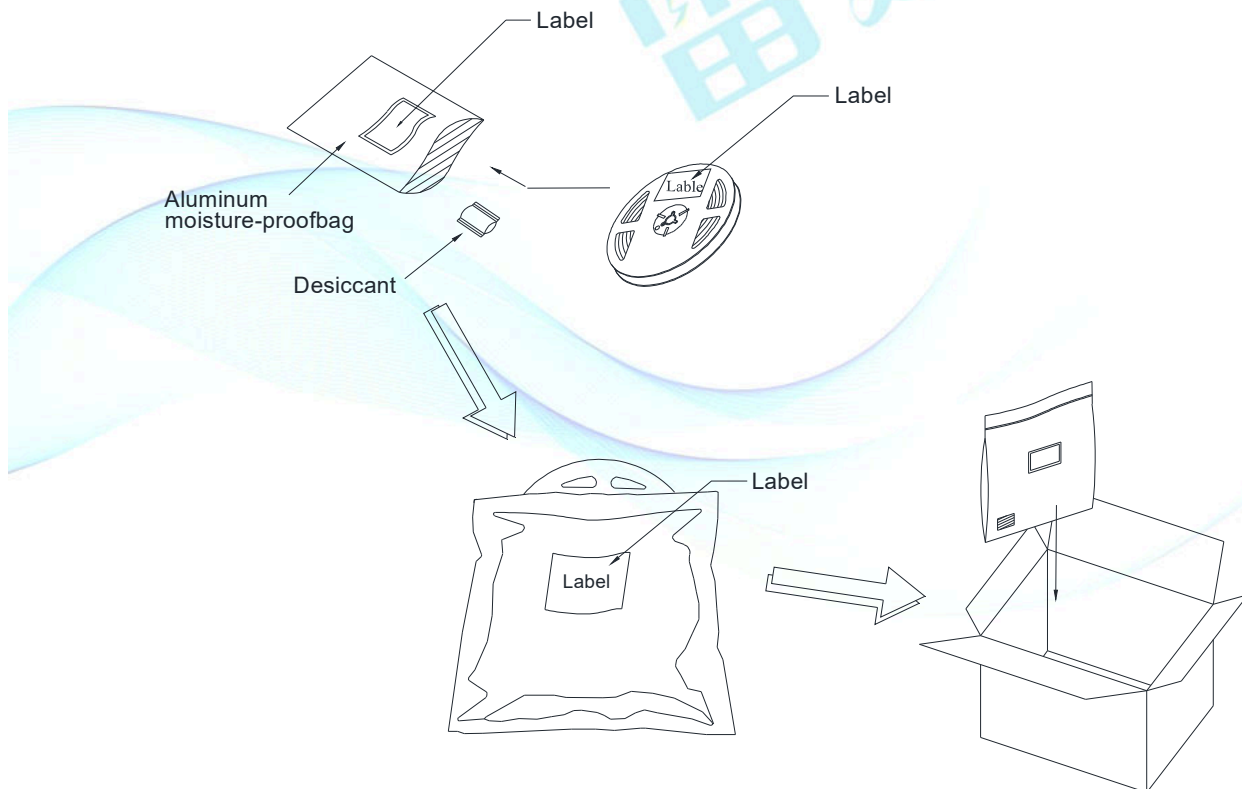

Moisture/Reflow sensitivity classification  
IPC / JEDEC J-STD-020C: Level 3

## Reliability Test Items and Conditions

The reliability of products shall be satisfied with items listed below.

Confidence level : 90%

LTPD : 10%

No.	Items	Test Condition	Test Hours/Cycles	Sample Size	Ac/Re
1	Reflow Soldering	Temp.: 260°C/10sec.	6 Min.	22 PCS.	0/1
2	Thermal Shock	H : +100°C/5min § 10 sec L : -10°C/5min	300 Cycles	22 PCS.	0/1
3	Temperature Cycle	H : +100°C/15min § 5 min L : -40°C/15min	300 Cycles	22 PCS.	0/1
4	High Temperature/Humidity Storage	Ta=85°C,85%RH	1000 Hrs.	22 PCS.	0/1
5	Low Temperature Storage	Ta=-40°C	1000 Hrs.	22 PCS.	0/1
6	High Temperature Storage	Ta=100°C	1000 Hrs.	22 PCS.	0/1
7	DC Operation Life	Ta=25°C, I <sub>F</sub> = 200 mA	1000 Hrs.	22 PCS.	0/1



## Precautions for Use

1. Over-current-proof  
Customer must apply resistors for protection; otherwise slight voltage shift will cause big current change (Burn out will happen).
2. Storage
  - 2.1 Do not open moisture proof bag before the products are ready to use.
  - 2.2 Before opening the package: The LEDs should be kept at 30°C or less and 90%RH or less.
  - 2.3 After opening the package: The LED's floor life is 168H under 30°C or less and 60%RH or less. If unused LEDs remain, it should be stored in moisture proof packages.
  - 2.4 If the moisture absorbent material (silica gel) has faded away or the LEDs have exceeded the storage time, baking treatment should be performed using the following conditions.  
Baking treatment: 60±5°C for 24 hours.
3. Soldering Condition
  - 3.1 Pb-free solder temperature profile

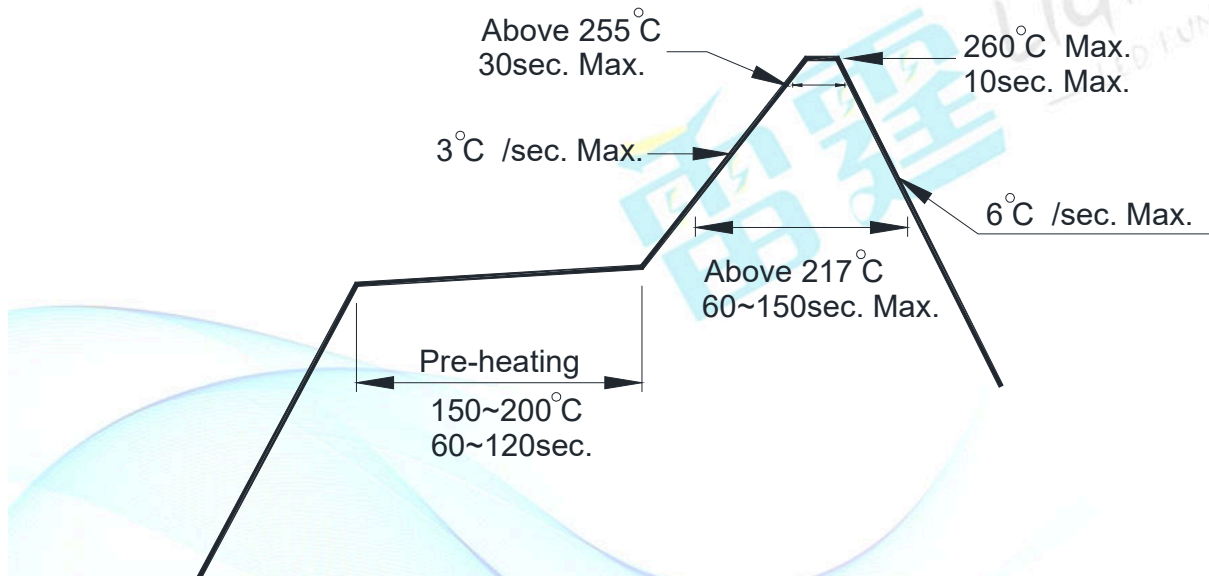

- 3.2 Reflow soldering should not be done more than two times.
- 3.3 When soldering, do not put stress on the LEDs during heating.
- 3.4 After soldering, do not warp the circuit board.
4. Soldering Iron  
Each terminal is to go to the tip of soldering iron temperature less than 350°C for 3 seconds within once in less than the soldering iron capacity 25W. Leave two seconds and more intervals and do soldering of each terminal. Be careful because the damage of the product is often started at the time of the hand solder.
5. Repairing  
Repair should not be done after the LEDs have been soldered. When repairing is unavoidable, a double-head soldering iron should be used (as below figure). It should be confirmed beforehand whether the characteristics of the LEDs will or will not be damaged by repairing