

<b>Customer Approved</b>
<b>Date:</b>

**Part No.:**  
**LL836W1D-H01T4**

**DATA SHEET**

Issue Date: 2018.09.07

Issue No.: LTD-836-001

REVISION: V3

Designer	Checker	Approver
<i>Vic</i>	<i>Felix</i>	<i>Jeff</i>

SMD Type ■ Top view 2835 Package  
LL836W1D-H01T4

**Features**

- 2835 package
- Top view LED
- High luminous flux output
- Compatible with infrared and vapor phase reflow solder process
- Pb-free
- RoHS compliant



**Package Dimensions**

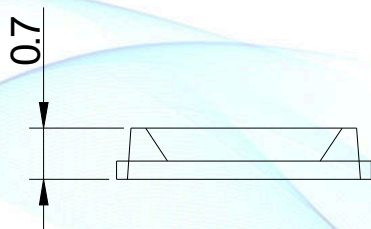
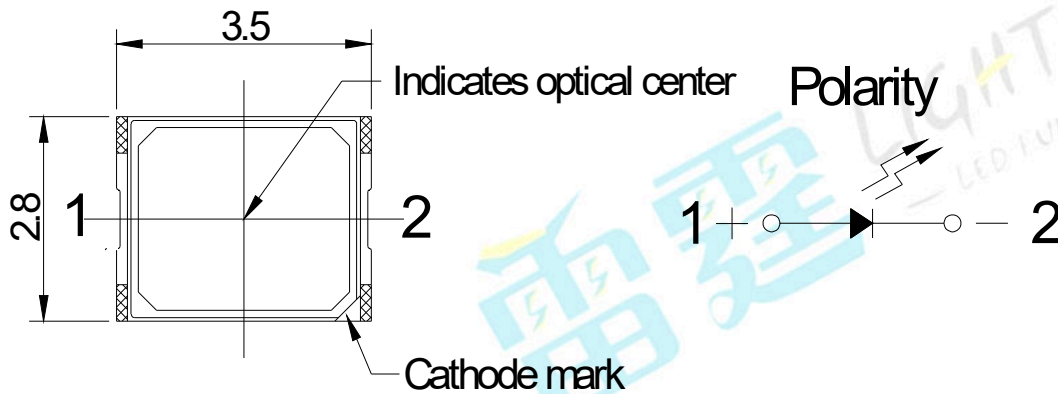

**Recommended solder pad**

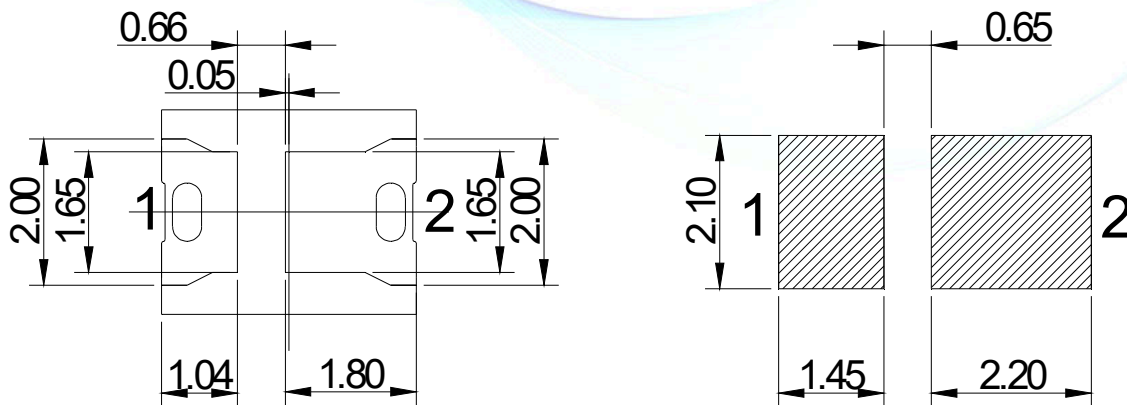

Note:  
Tolerance unless mentioned is  $\pm 0.1$ mm, Unit = mm.

### Applications

- Flash lights
- General lighting
- Decorative and Entertainment Lighting
- Indicators
- Illumination
- Automotive Telecommunication
- Switch lights

### Absolute Maximum Ratings (T<sub>Soldering</sub>=25°C)

Parameter	Symbol	Rating	Unit
Forward Current	I <sub>F</sub>	150	mA
Peak Forward Current (T=1ms, tp=0.1ms)	I <sub>FP</sub>	180	mA
Power Dissipation	P <sub>d</sub>	0.5	W
Operating Temperature	T <sub>opr</sub>	-40 ~ +85	°C
Storage Temperature	T <sub>stg</sub>	-40 ~ +100	°C
Soldering Temperature	T <sub>sol</sub>	Reflow Soldering : 260 °C for 10 sec. Hand Soldering : 350 °C for 3 sec.	
Reverse Voltage	V <sub>R</sub>	5	V

**Note:**

The products are sensitive to static electricity and must be carefully taken when handling products.

### Electro-Optical Characteristics (T<sub>Soldering</sub>=25°C)

Parameter	Symbol	Min.	Typ.	Max.	Unit	Condition
Luminous Flux	Φ	28	-----	32	lm	I <sub>F</sub> =60mA
Forward Voltage	V <sub>F</sub>	2.8	-----	3.2	V	I <sub>F</sub> =60mA
Color Temperature	T <sub>c</sub>	6000	-----	6500	K	I <sub>F</sub> =60mA
Ra	----	80	-----	-----	-----	I <sub>F</sub> =60mA
Viewing Angle	2θ <sub>1/2</sub>	-----	120	-----	deg	I <sub>F</sub> =60mA
Reverse Current	I <sub>R</sub>	-----	-----	5	μA	V <sub>R</sub> =5V

**Notes:**

1. Tolerance of Luminous Flux: ±10%.
2. Color Temperature ±100K.
3. Tolerance of Forward Voltage : ±0.05V..

## Bin Code Description

### Bin Range of Forward Voltage

Bin Code	Min.	Max.	Unit	Condition
35	2.8	2.9	V	I <sub>F</sub> =60mA
36	2.9	3.0		
37	3.0	3.1		
38	3.1	3.2		

Note:  
Tolerance of Forward Voltage : ±0.05V.

### Bin Range of Chromaticity Coordinates

CCT	Bin Code	CIE-X	CIE-Y
6000K	B60-3	0.3201	0.3500
		0.3206	0.3399
		0.3118	0.3310
		0.3114	0.3411
		Reference Range: SDCM <3	
		0.3221	0.3538
	B60-4	0.3227	0.3403
		0.3099	0.3271
		0.3093	0.3409
		Reference Range: SDCM <4	
		0.3240	0.3576
		0.3248	0.3406
	B60-6	0.3080	0.3232
		0.3072	0.3406
		Reference Range: SDCM <6	

- Notes:
1. The value is based on driving current by 60mA.
  2. Tolerance of Chromaticity Coordinates: ±0.01.

## The C.I.E. 1931 Chromaticity Diagram

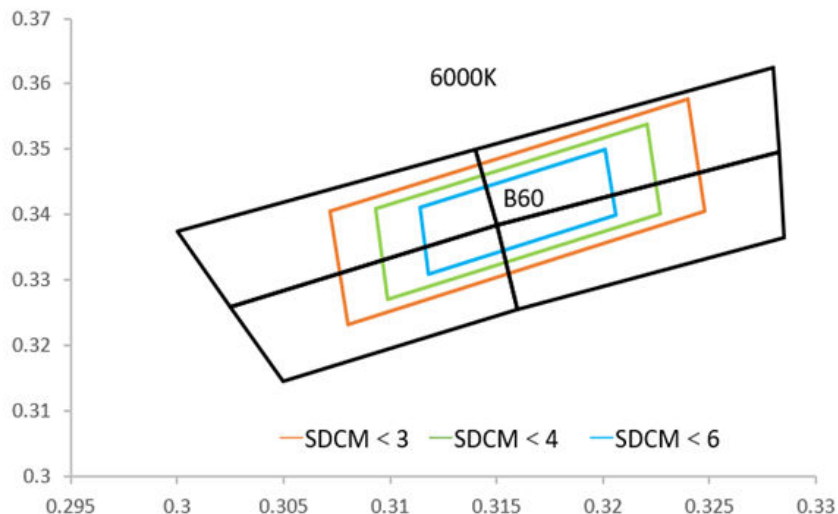

**Typical Electro-Optical Characteristics Curves**

Fig.1-Forward Current(V) vs. Forward Voltage  $T_s=25\text{ C}$

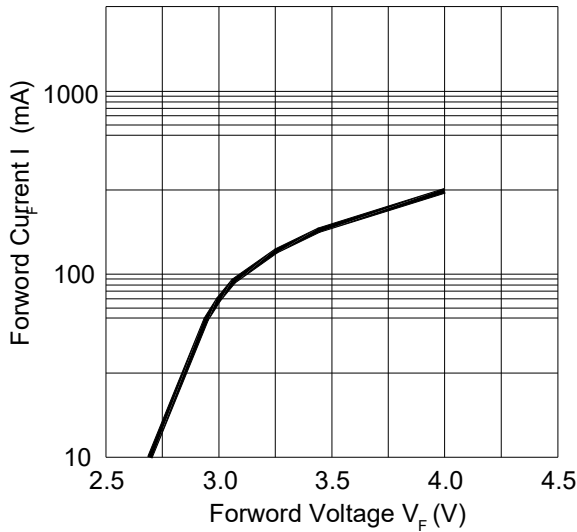

Fig.2-Relative Luminous Flux vs. Forward Current  $T_s=25\text{ C}$

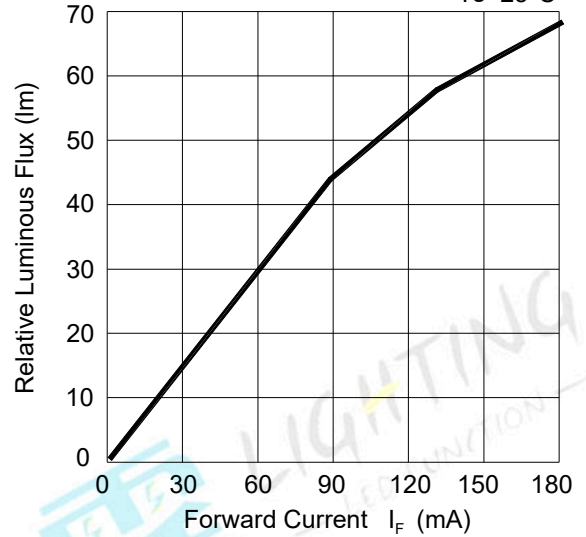

Fig.3-Max.Driving Forward Current vs.Soldering Temperature

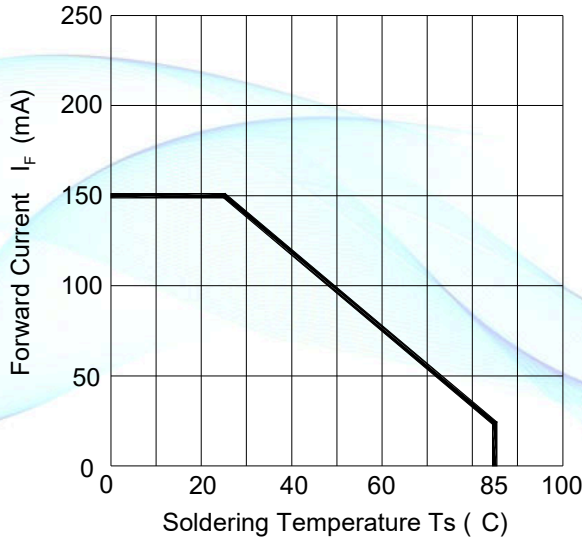
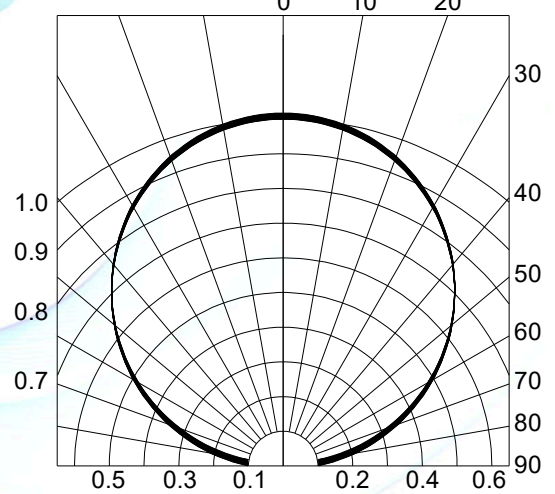

Fig.4-Radiation Diagram  $T_a=25\text{ C}$



**Typical Electro-Optical Characteristics Curves**

Fig.5-Forward Voltage Shift vs. Junction Temperature

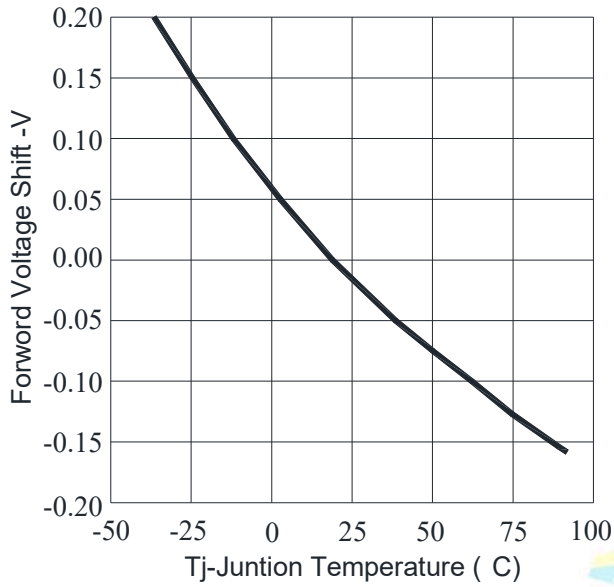
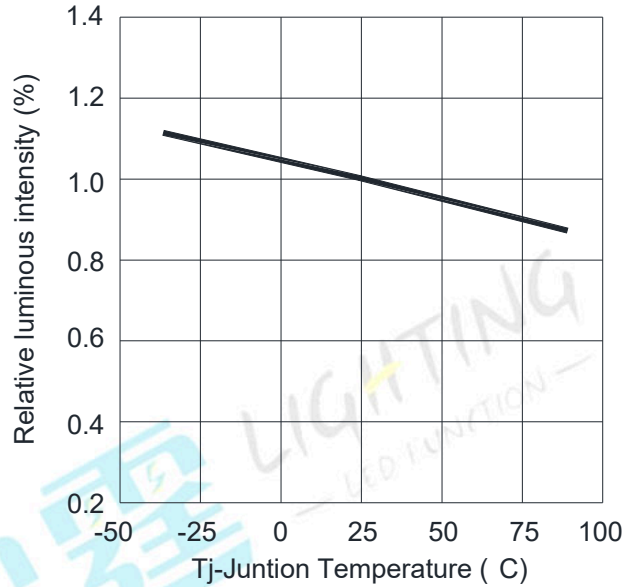
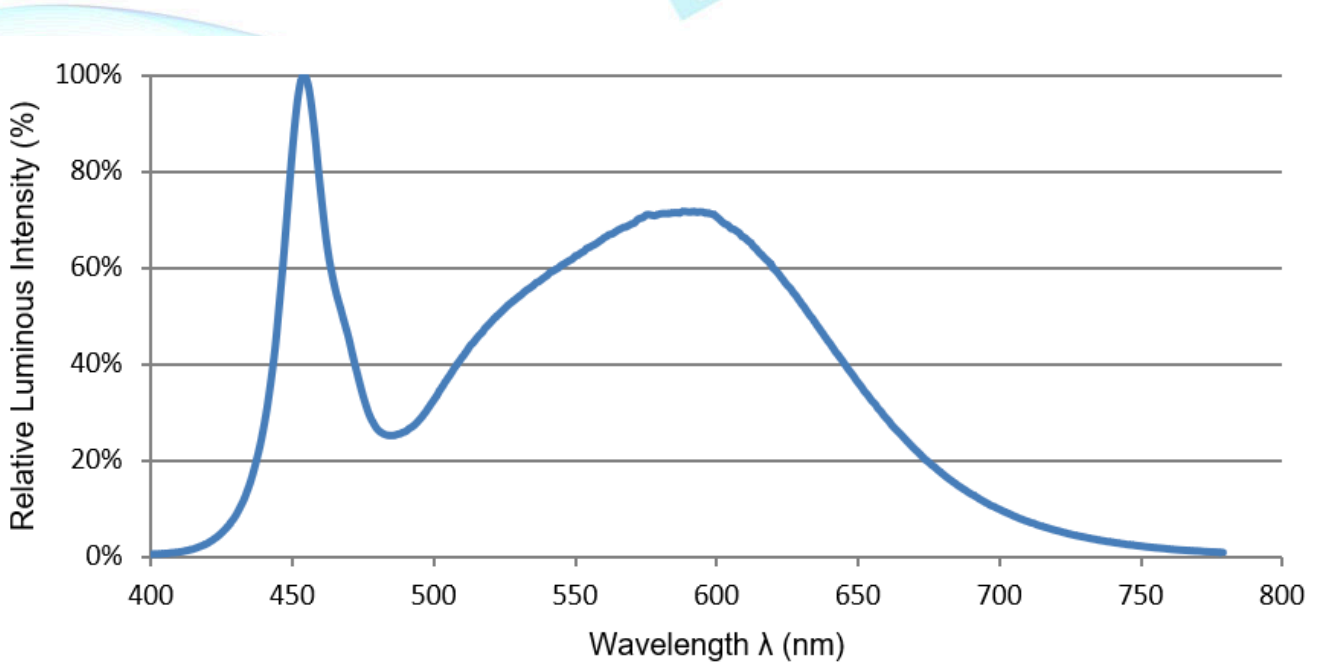

Fig.6-Relative Luminous Flux vs. Junction Temperature



**Spectrum Distribution**



**Moisture Resistant Packing Materials**

**Label Explanation**



- \* QR code:  
Contains all of the following information
- \* P/N: Product Number
- \* TYPE :Part NO.
- \* IV: Luminous Flux Rank
- \* HUE:Chromaticity Coordinates Rank
- \* VF: Forward Voltage Rank
- \* QTY: Packing Quantity
- \* LOT NO.: Lot Number

**Taping method: Loaded Quantity 4,000 pcs Per Reel**

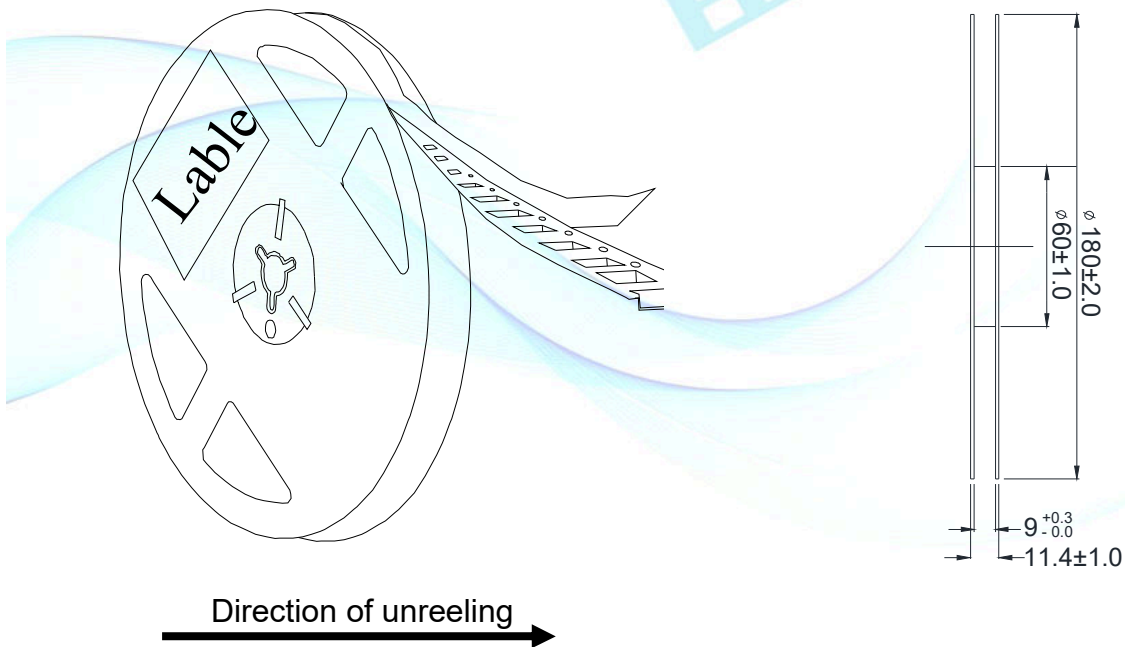

- Notes:
- 1.Tolerance unless mentioned is ±0.1mm,Unit = mm.
  - 2.Minimum packing amount is 1000 pcs per reel.

**Carrier Tape Dimensions:**

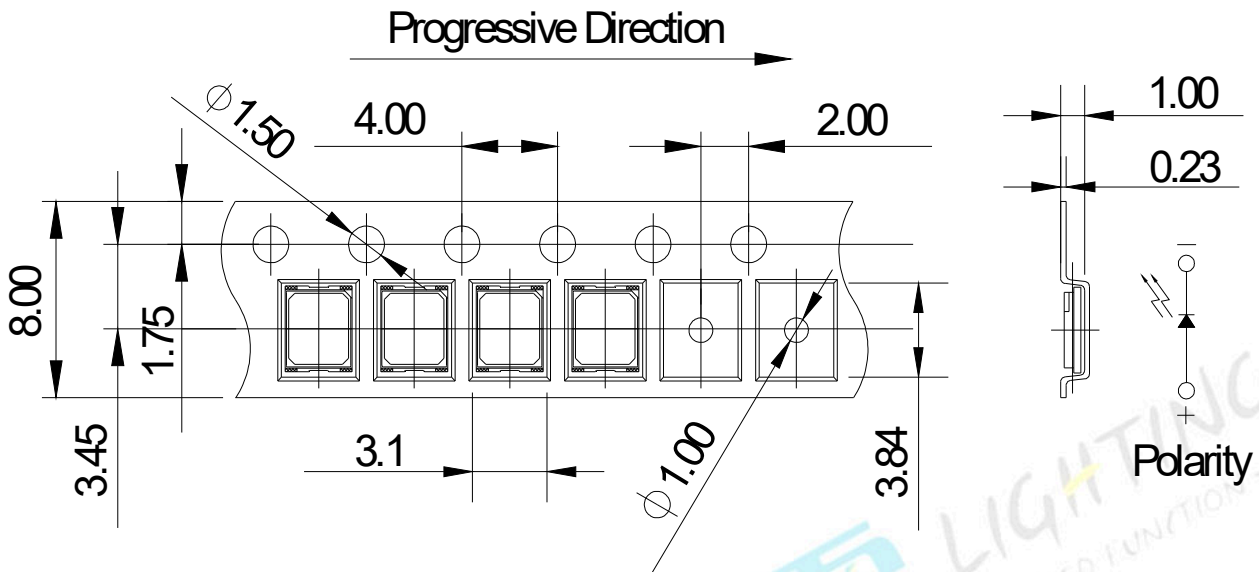

Note:  
Tolerance unless mentioned is  $\pm 0.1$ mm, Unit = mm.

**Moisture Resistant Packing Process**

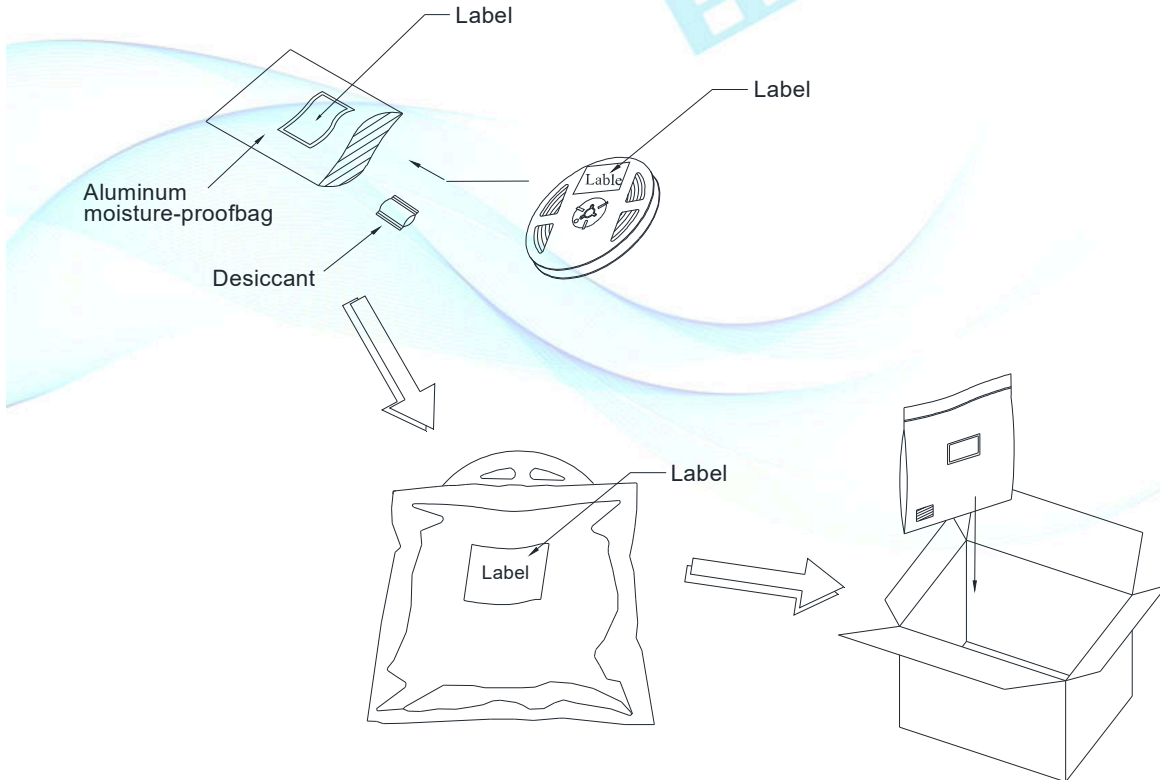

Moisture/Reflow sensitivity classification

IPC / JEDEC J-STD-020C: Level 5a



**Reliability Test Items and Conditions**

The reliability of products shall be satisfied with items listed below.

Confidence level : 90%

LTPD : 10%

No.	Items	Test Condition	Test Hours/Cycles	Sample Size	Ac/Re
1	Reflow Soldering	Temp.: 260°C/10sec.	6 Min.	22 PCS.	0/1
2	Thermal Shock	H : +100°C/5min ∩ 10 sec L : -10°C/5min	300 Cycles	22 PCS.	0/1
3	Temperature Cycle	H : +100°C/15min ∩ 5 min L : -40°C/15min	300 Cycles	22 PCS.	0/1
4	High Temperature/Humidity Storage	Ta=85°C,85%RH	1000 Hrs.	22 PCS.	0/1
5	Low Temperature Storage	Ta=-40°C	1000 Hrs.	22 PCS.	0/1
6	High Temperature Storage	Ta=100°C	1000 Hrs.	22 PCS.	0/1
7	DC Operation Life	Ta=25°C, I <sub>F</sub> = 60 mA	1000 Hrs.	22 PCS.	0/1



## Precautions for Use

### 1. Over-current-proof

Customer must apply resistors for protection; otherwise slight voltage shift will cause big current change (Burn out will happen).

### 2. Storage

2.1 Do not open moisture proof bag before the products are ready to use.

2.2 Before opening the package: The LEDs should be kept at 30°C or less and 90%RH or less.

2.3 After opening the package: The LED's floor life is 24Hrs. under 30°C or less and 60%RH or less. If unused LEDs remain, it should be stored in moisture proof packages.

2.4 If the moisture absorbent material (silica gel) has faded away or the LEDs have exceeded the storage time, baking treatment should be performed using the following conditions.

Baking treatment: 60±5°C for 24 hours.

### 3. Soldering Condition

#### 3.1 Pb-free solder temperature profile

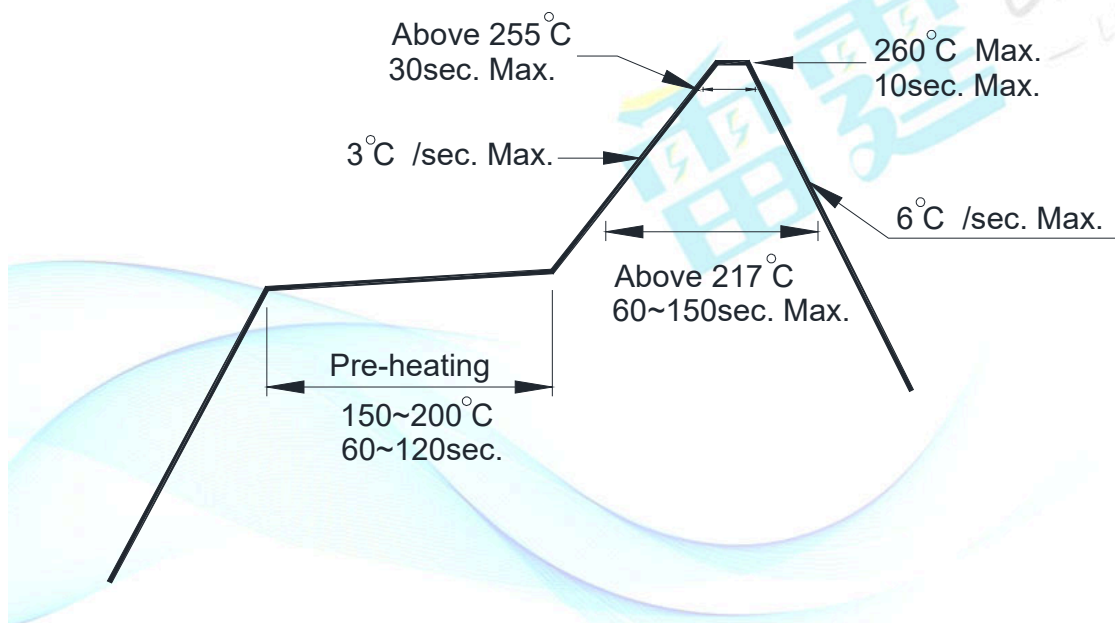

3.2 Reflow soldering should not be done more than two times.

3.3 When soldering, do not put stress on the LEDs during heating.

3.4 After soldering, do not warp the circuit board.

### 4. Soldering Iron

Each terminal is to go to the tip of soldering iron temperature less than 350°C for 3 seconds within once in less than the soldering iron capacity 25W. Leave two seconds and more intervals and do soldering of each terminal. Be careful because the damage of the product is often started at the time of the hand solder.

### 5. Repairing

Repair should not be done after the LEDs have been soldered. When repairing is unavoidable, a double-head soldering iron should be used (as below figure). It should be confirmed beforehand whether the characteristics of the LEDs will or will not be damaged by repairing.