

Customer Approved
Date:

Part No.:
LA330GHW-A01

DATA SHEET

Issue Date: 2018.08.17
Issue No.: LDE-SA3-006
REVISION: V2

Designer	Checker	Approver
<i>Vic</i>	<i>Rock</i>	<i>Allen</i>

Lamp LED Type ■ 3.0mm Dia LED LAMP
LA330GHW-A01

Features

- 3.0mm Dia LED LAMP
- Pb-free
- RoHS compliant

Package Dimensions

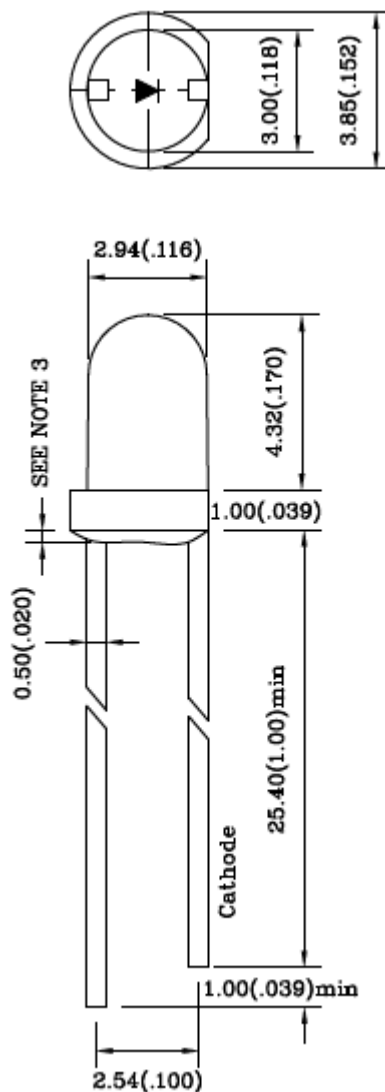

Note:
Tolerance unless mentioned is ± 0.25 mm, Unit = mm.

Applications

- General lighting
- Decorative and Entertainment Lighting
- Indicators
- Automotive Telecommunication
- Switch lights

Absolute Maximum Ratings (T_{Soldering}=25°C)

Parameter	Symbol	Rating	Unit
Forward Current	I _F	30	mA
Peak Forward Current (Duty 1/10 @1ms)	I _{FP}	120	mA
Power Dissipation	P _d	100	mW
Operating Temperature	T _{opr}	-25 ~ +85	°C
Storage Temperature	T _{stg}	-40 ~ +85	°C
Soldering Temperature	T _{sol}	Reflow Soldering : 260°C for 10 sec. Hand Soldering : 350°C for 3 sec.	
Reverse Voltage	V _R	5	V

Note:
The products are sensitive to static electricity and must be carefully taken when handling products.

Electro-Optical Characteristics (T_{Soldering}=25°C)

Parameter	Symbol	Min.	Typ.	Max.	Unit	Condition
Luminous Intensity	IV	-	6000	-	mcd	IF=20mA
Dominant Wavelength	λD	525	-	530	nm	IF=20mA
Forward Voltage	VF	2.8	-	3.4	V	IF=20mA
Viewing Angle	2θ1/2	-	50	-	deg	IF=20mA
Reverse Current	IR	-	-	10	μA	VR =5V

- Notes:
1. Tolerance of Luminous Intensity ±10%.
 2. Tolerance of Dominant Wavelength : ±1nm.
 3. Tolerance of Forward Voltage : ±0.1V.

Typical Electro-Optical Characteristics Curves

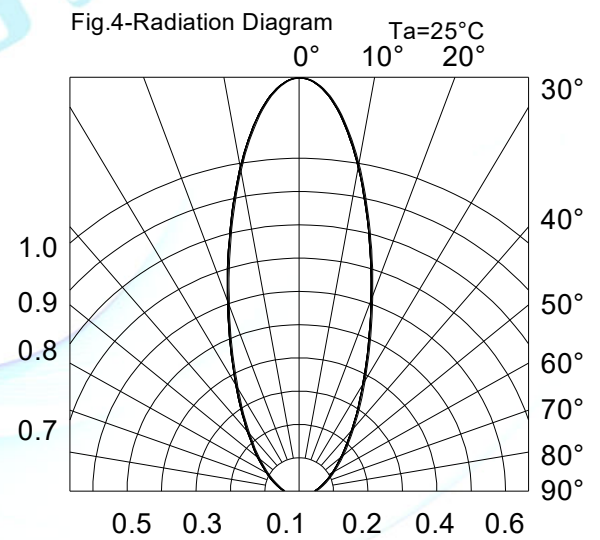
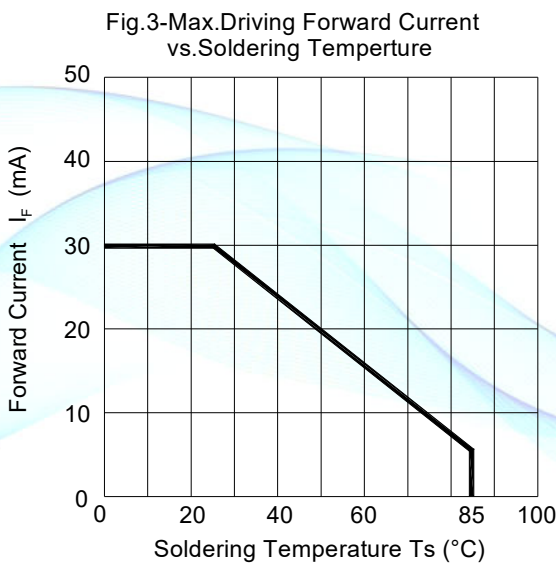
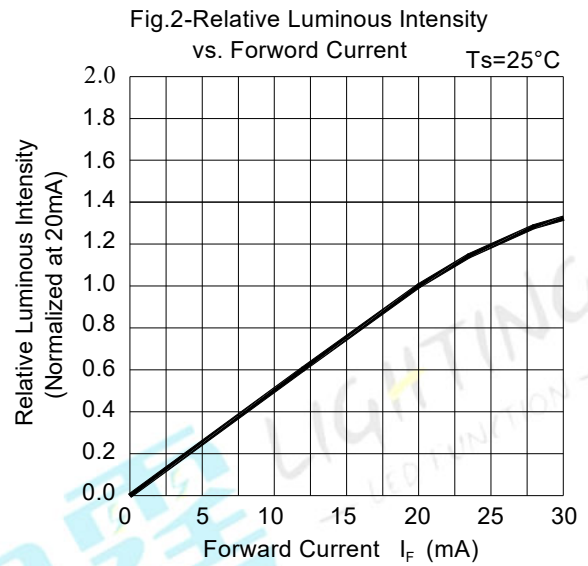
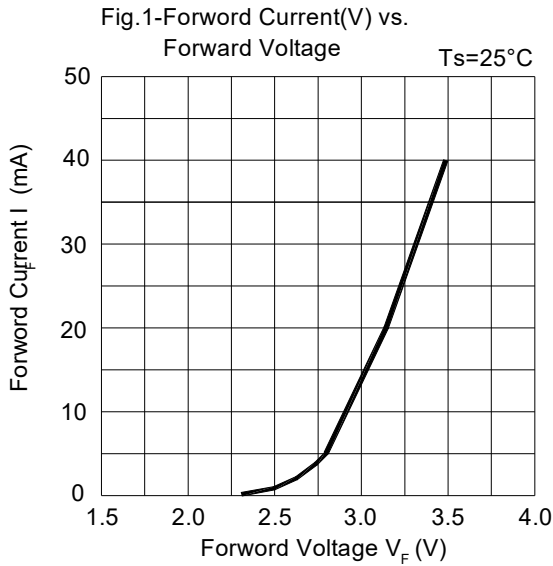

Typical Electro-Optical Characteristics Curves

Fig.5-Forward Voltage Shift vs. Junction Temperature

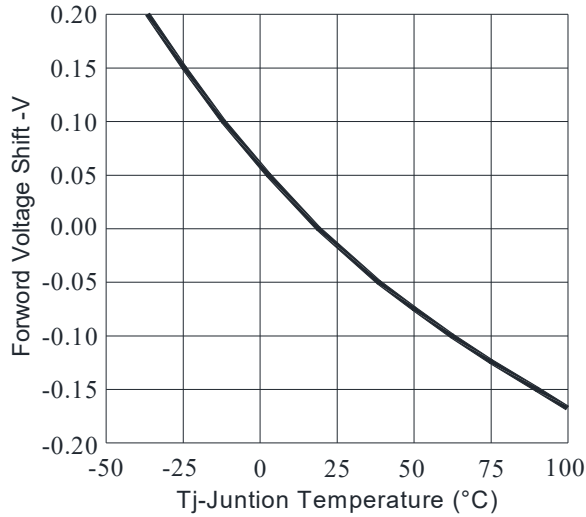
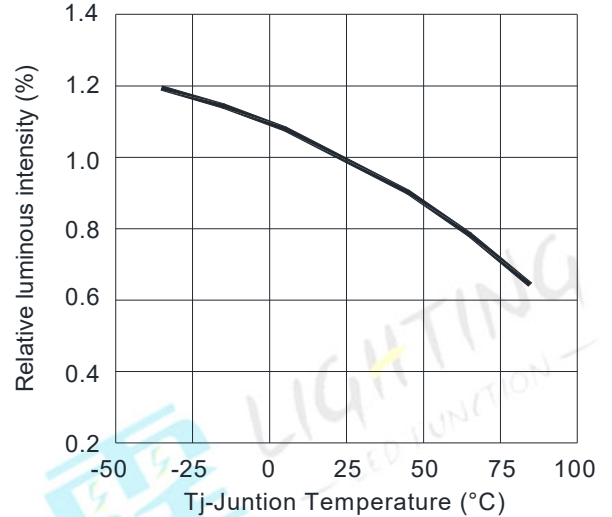
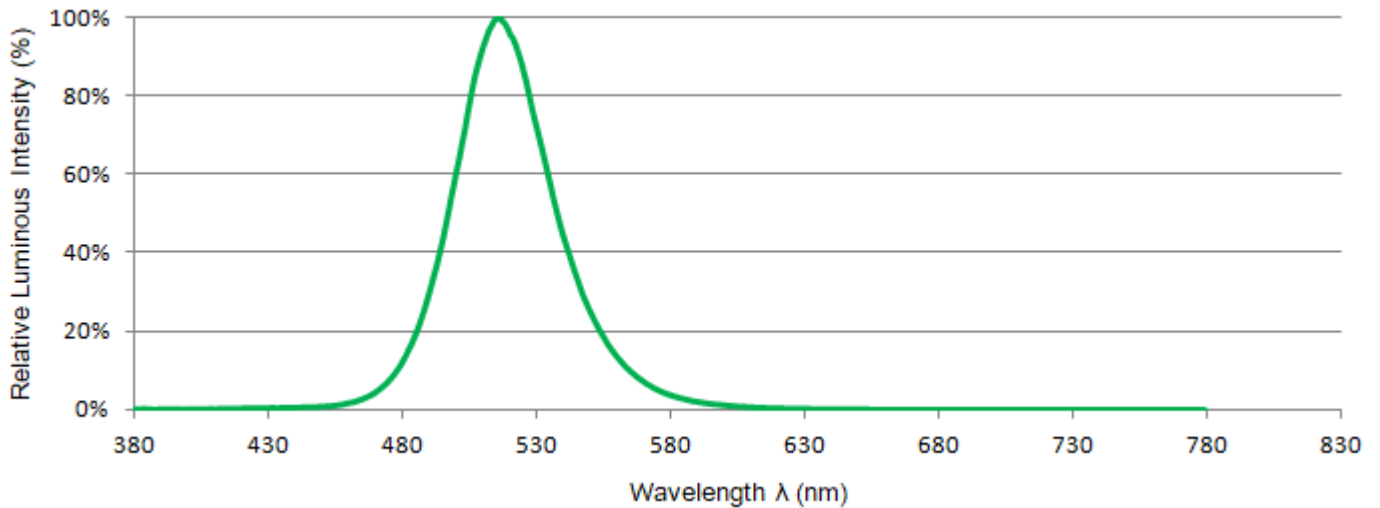

Fig.6-Relative Luminous Intensity vs. Junction Temperature



Spectrum Distribution



Moisture Resistant Packing Materials

Label Explanation



- QR code:
Contains all of the following information
- P/N: Product Number
- TYPE :Part NO.
- IV: Luminous Intensity Rank
- WD: Wavelength Rank
- VF: Forward Voltage Rank
- QTY: Packing Quantity
- LOT NO.: Lot Number

Moisture Resistant Packing Process : 1000 PCS/Bag

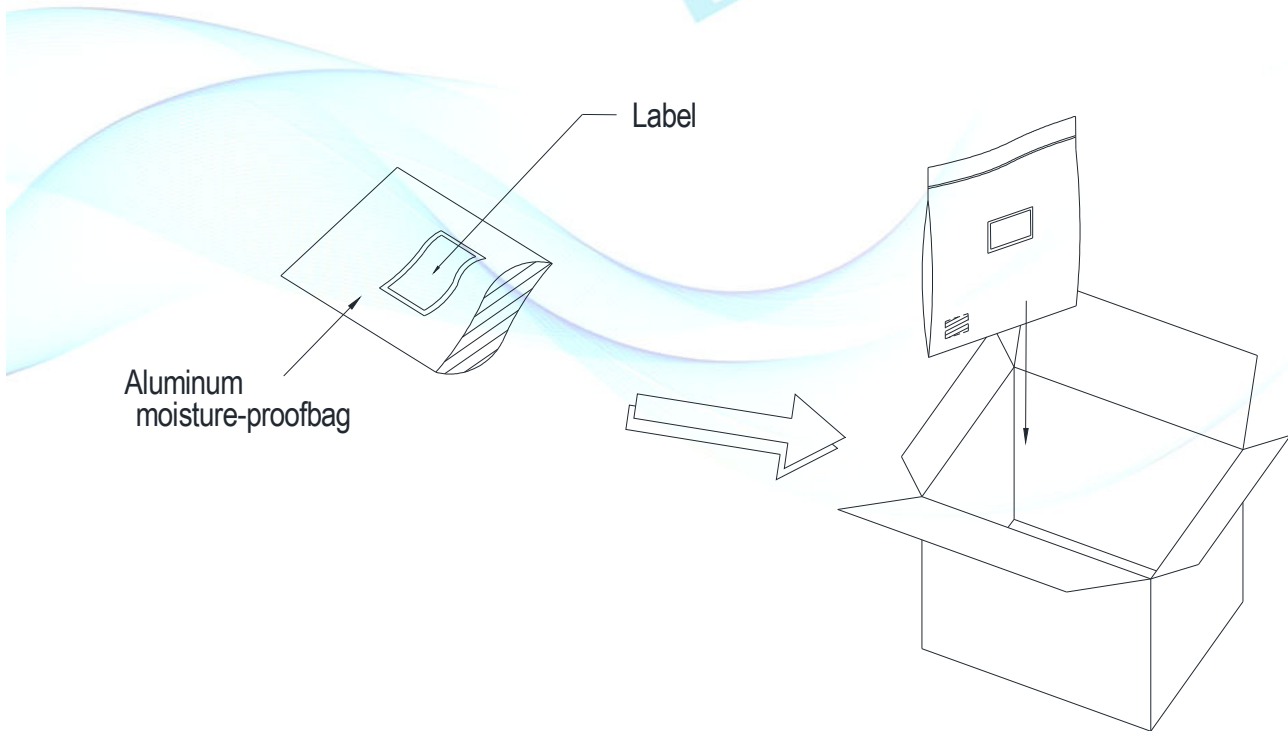

Reliability Test Items and Conditions

The reliability of products shall be satisfied with items listed below.

Confidence level : 90%

LTPD : 10%

No.	Items	Test Condition	Test Hours/Cycles	Sample Size	Ac/Re
1	Wave Soldering	T, sol:260°C/5sec	3 min. Max.	22PCS	0/1
2	Solderability	T, sol:230°C/5sec	60 sec. Max.	22PCS	0/1
3	Thermal Shock	H : +105°C 10min ↓ L : -55°C 10min	10 Cycles	22 PCS.	0/1
4	Temperature Cycle	H : +105°C 30min ↓ 25°C 5min ↓ L : -55°C 30min ↓ 25°C 5min	10 Cycles	22 PCS.	0/1
5	High Temperature/Humidity Reverse Bias	Ta=65°C,90%RH	240 Hrs.	22 PCS.	0/1
6	DC Operation Life	Ta=25°C, I _F = 20 mA	1000 Hrs.	22 PCS.	0/1

Precautions for Use

1. Over-current-proof
Customer must apply resistors for protection; otherwise slight voltage shift will cause big current change (Burn out will happen).
2. Storage
 - 2.1 Do not open moisture proof bag before the products are ready to use.
 - 2.2 Before opening the package: The LEDs should be kept at 30°C or less and 90%RH or less.
 - 2.3 After opening the package: The LED's floor life is 1 year under 30°C or less and 60% RH or less. If unused LEDs remain, it should be stored in moisture proof packages.
 - 2.4 If the moisture absorbent material (silica gel) has faded away or the LEDs have exceeded the storage time, baking treatment should be performed using the following conditions.
Baking treatment: 60±5°C for 24 hours.
3. Soldering

Method	Remark
Hand Soldering	1. Soldering time : 3 sec MAX. 2. Distance : 3 mm MIN (from solder joint to case)
DIP Soldering	1. Preheat temp : 100 °C MAX , 60 sec MAX. 2. Bath temp : 260 °C MAX. 3. Bath time : 5 sec MAX. 4. Distance : 3 mm MIN (From solder joint to case.)

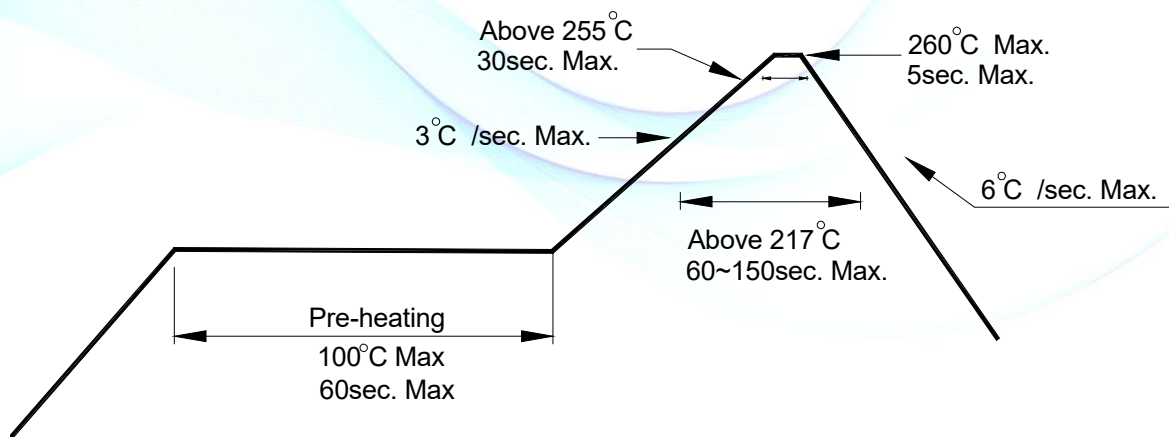

4. Cleaning
Do not use unspecified chemical liquid to clean LED. They could harm it IF cleaning is necessary, wipe the pin out with alcohol, Freon TE or Chlorosen at normal temperature for less than 1 minute or wipe the surface with alcohol.

5. Methods Antistatic Static Electricity

Static electricity is the enemy of lamps emitting blue and green. Workers must put on working rings, gloves clothes hat protect static electricity while working. Wires of the rings keep well together with the floor and there must be wires to connect the irons and the floor.

6. Over-current-proof

6-1. Be not over-current.

6-2. In order to cooperate LEDs under stable conditions, put protective resistor in series. Resistor values can be determined by supplying voltage or current for the LEDs Recommended current is in the range of forward current 5mA-20mA.

6-3. Circuit must be designed so that overvoltage is not applied the LED during on/off switching. Transient or pulse current will damage junction of LED die.

7. Soldering Iron

Each terminal is to go to the tip of soldering iron temperature less than 300°C for 3 seconds within once in less than the soldering iron capacity 30W. Leave two seconds and more intervals, and do soldering of each terminal. Be careful because the damage of the product is often started at the time of the hand solder.

8. Repairing

Repair should not be done after the LEDs have been soldered. When repairing is unavoidable, a double-head soldering iron should be used (as below figure). It should be confirmed beforehand whether the characteristics of the LEDs will or will not be damaged by repairing.